



US007635370B2

(12) **United States Patent**
Michelson

(10) **Patent No.:** **US 7,635,370 B2**
(45) **Date of Patent:** ***Dec. 22, 2009**

- (54) **BONE REMOVAL DEVICE**
- (75) Inventor: **Gary K. Michelson**, Venice, CA (US)
- (73) Assignee: **Warsaw Orthopedic, Inc.**, Warsaw, IN (US)
- (*) Notice: Subject to any disclaimer, the term of this patent is extended or adjusted under 35 U.S.C. 154(b) by 0 days.

5,059,194 A	10/1991	Michelson	
5,201,749 A	4/1993	Sachse et al.	
5,207,680 A *	5/1993	Dietz et al.	606/86
5,356,414 A	10/1994	Cohen et al.	
5,439,005 A	8/1995	Vaughn	
5,474,559 A	12/1995	Bertin et al.	
5,484,437 A	1/1996	Michelson	
5,484,446 A	1/1996	Burke et al.	

This patent is subject to a terminal disclaimer.

(Continued)

(21) Appl. No.: **10/852,449**

FOREIGN PATENT DOCUMENTS

(22) Filed: **May 24, 2004**

EP 0 641 547 3/1995

(65) **Prior Publication Data**

US 2004/0215203 A1 Oct. 28, 2004

(Continued)

Related U.S. Application Data

OTHER PUBLICATIONS

- (63) Continuation of application No. 10/090,506, filed on Feb. 27, 2002, now Pat. No. 7,083,623, which is a continuation of application No. 09/734,303, filed on Dec. 12, 2000, now Pat. No. 6,440,139, which is a continuation of application No. 08/688,758, filed on Jul. 31, 1996, now Pat. No. 6,159,214.

US 5,612,970, 03/1997, Houston et al. (withdrawn)

Primary Examiner—Darwin P Erezzo
Assistant Examiner—Melissa Ryckman
(74) *Attorney, Agent, or Firm*—Martin & Ferraro, LLP

(51) **Int. Cl.**
A61B 17/60 (2006.01)

(57) **ABSTRACT**

- (52) **U.S. Cl.** 606/96; 606/86 R; 606/99
 - (58) **Field of Classification Search** 606/61, 606/86, 96, 99
- See application file for complete search history.

An apparatus and method for placing adjacent vertebrae at a fixed distance and angular relationship relative to each other, fixing said vertebrae in said position by use of a milling block engaging each of said adjacent vertebrae and then using a milling means, the depth, length and excursion of which from side to side are controlled by said apparatus to machine out a defined thickness of bone and a space of defined length, height, width and shape in preparation for receiving an interbody spinal implant or graft of known size and configuration are disclosed.

(56) **References Cited**
U.S. PATENT DOCUMENTS

3,236,275 A	2/1966	Smith
3,384,085 A	5/1968	Hall
3,978,862 A	9/1976	Morrison
4,359,318 A	11/1982	Gittleman
4,545,374 A	10/1985	Jacobson

42 Claims, 23 Drawing Sheets

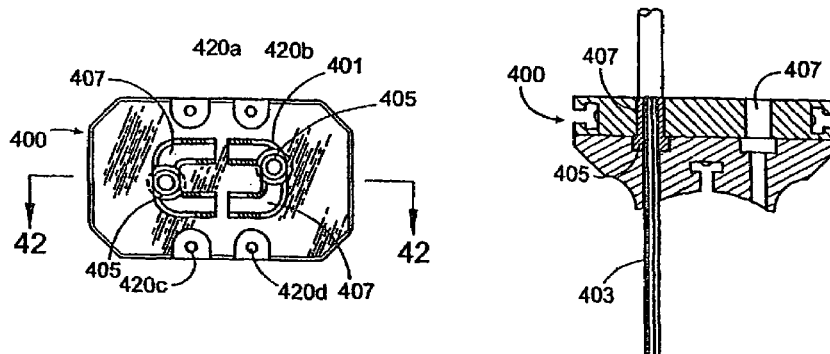

US 7,635,370 B2

Page 2

U.S. PATENT DOCUMENTS

5,486,180	A	1/1996	Dietz et al.	5,688,281	A	11/1997	Cripe et al.	
5,489,307	A	2/1996	Kuslich	5,853,415	A *	12/1998	Bertin et al.	606/80
5,505,732	A	4/1996	Michelson	5,910,143	A	6/1999	Cripe et al.	
5,534,005	A	7/1996	Tokish, Jr. et al.	6,080,155	A	6/2000	Michelson	
5,571,109	A *	11/1996	Bertagnoli					606/61
5,613,970	A	3/1997	Houston et al.					
5,653,714	A	8/1997	Dietz et al.					

FOREIGN PATENT DOCUMENTS

EP 1 120 089 8/2001

* cited by examiner

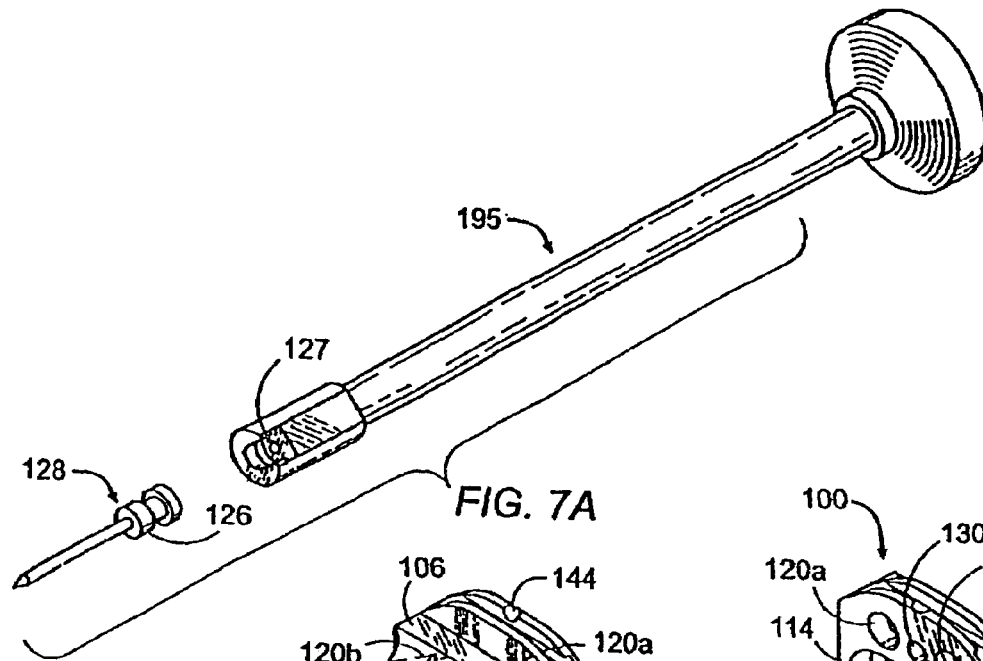

FIG. 7A

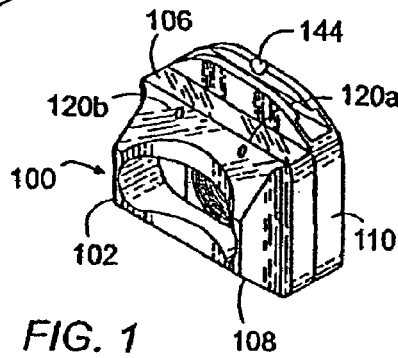

FIG. 1

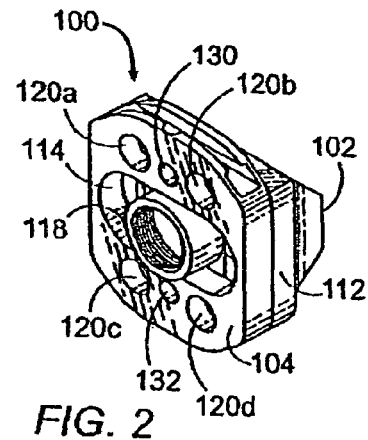

FIG. 2

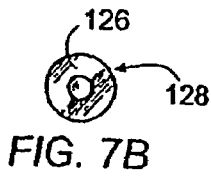

FIG. 7B

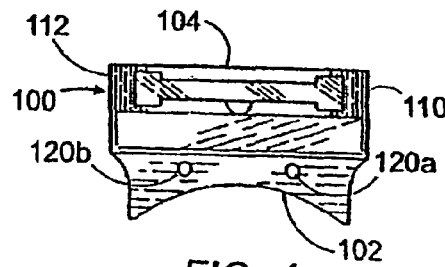

FIG. 4

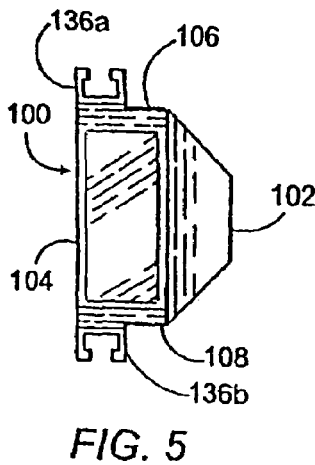

FIG. 5

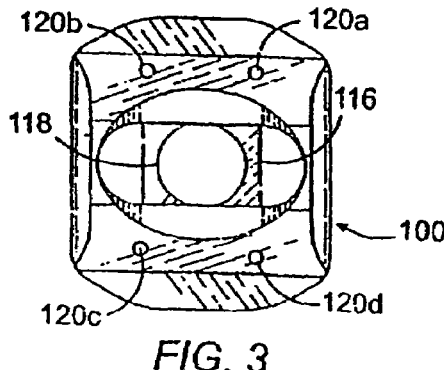

FIG. 3

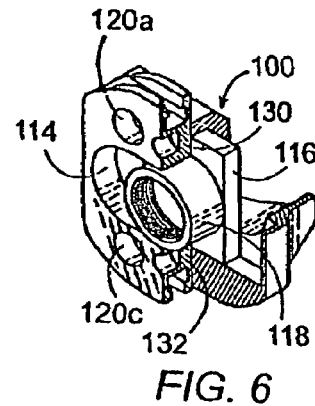
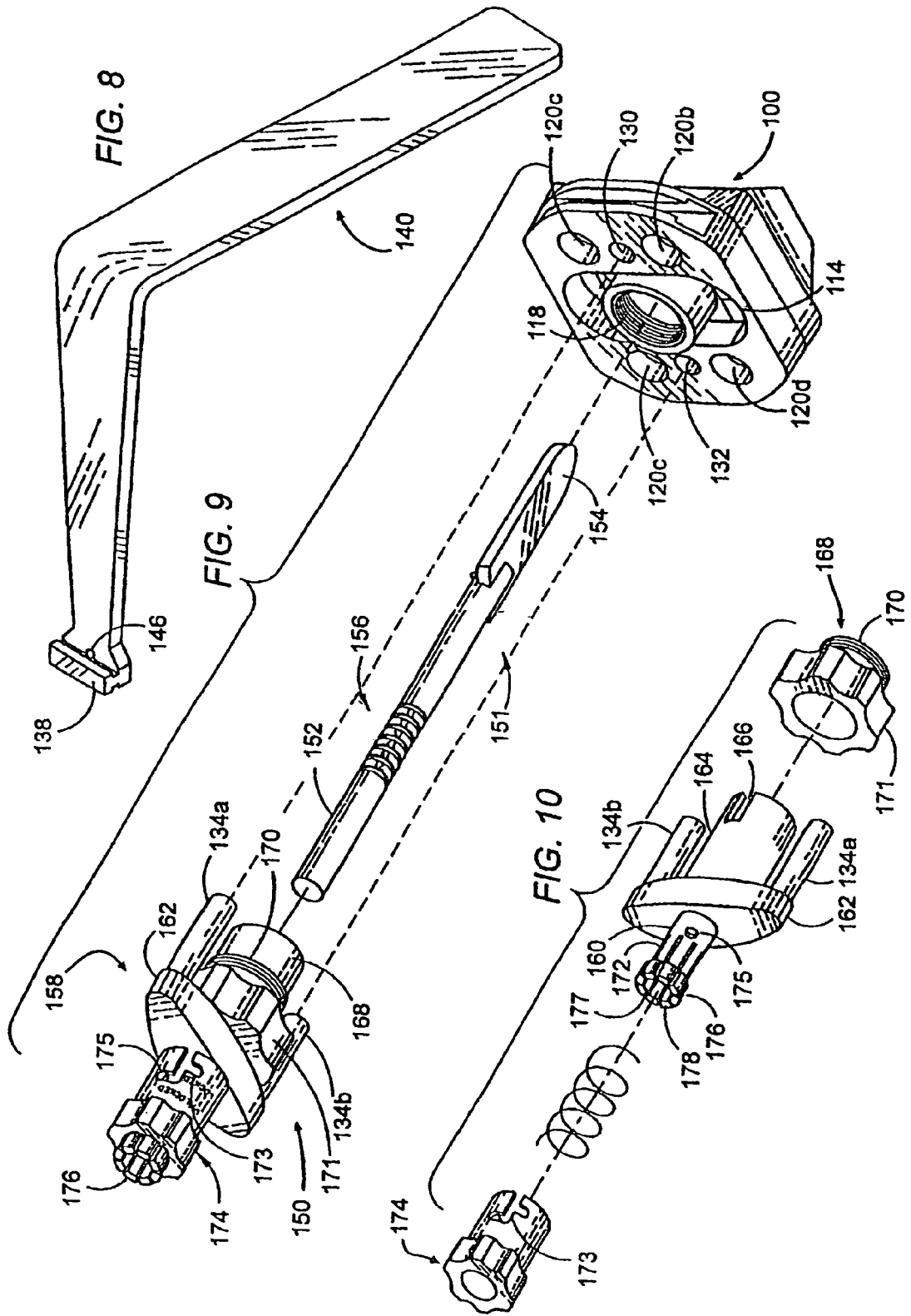
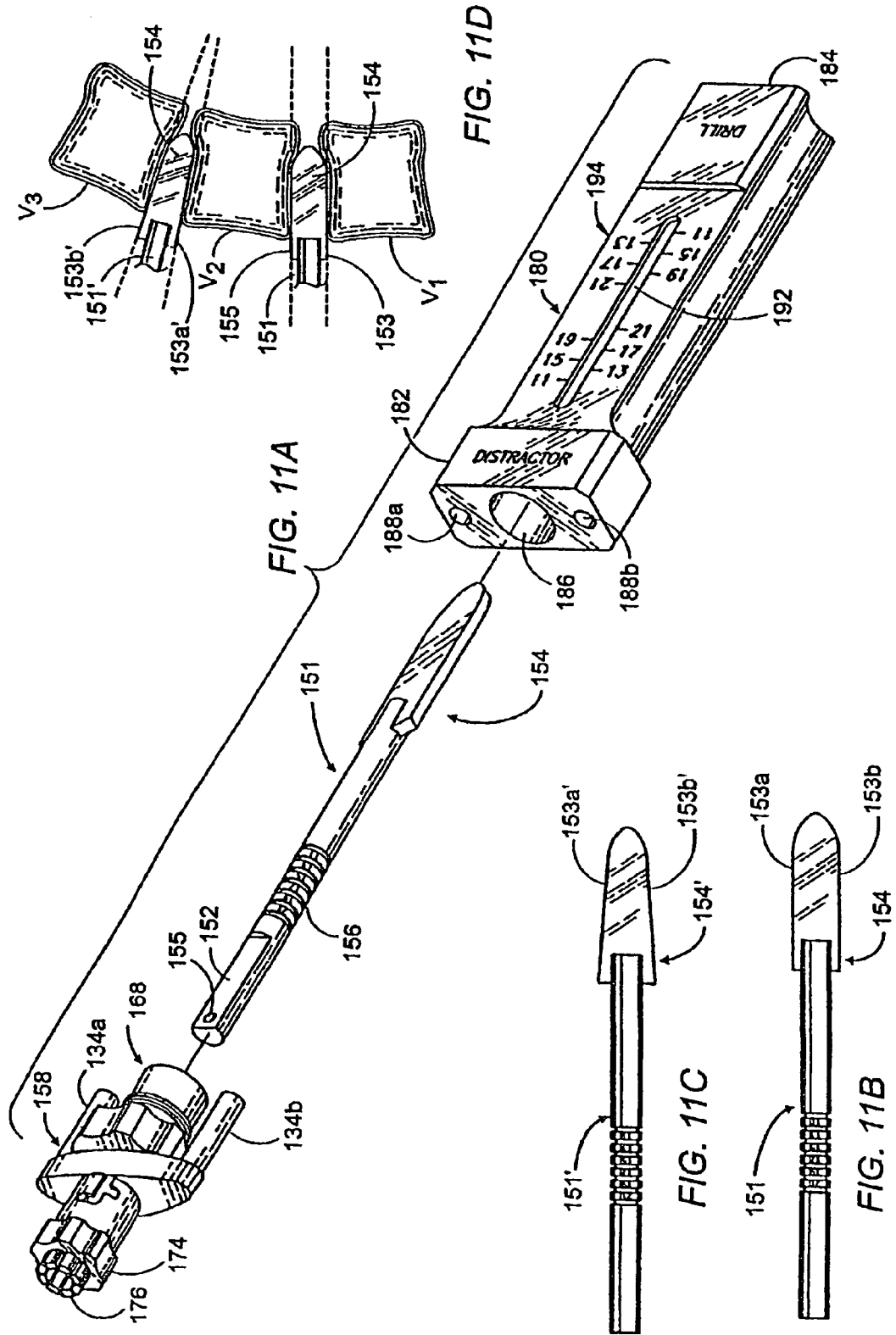

FIG. 6





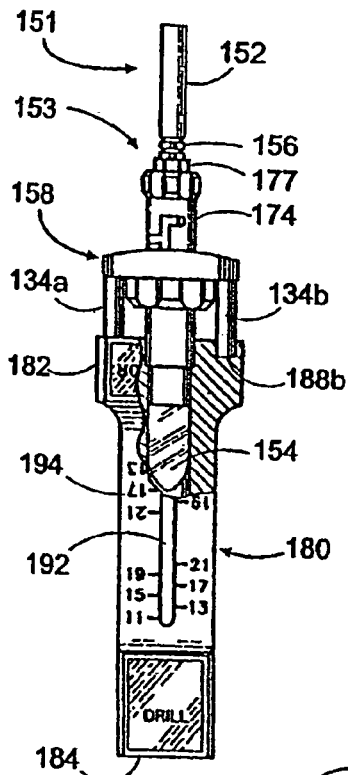

FIG. 12

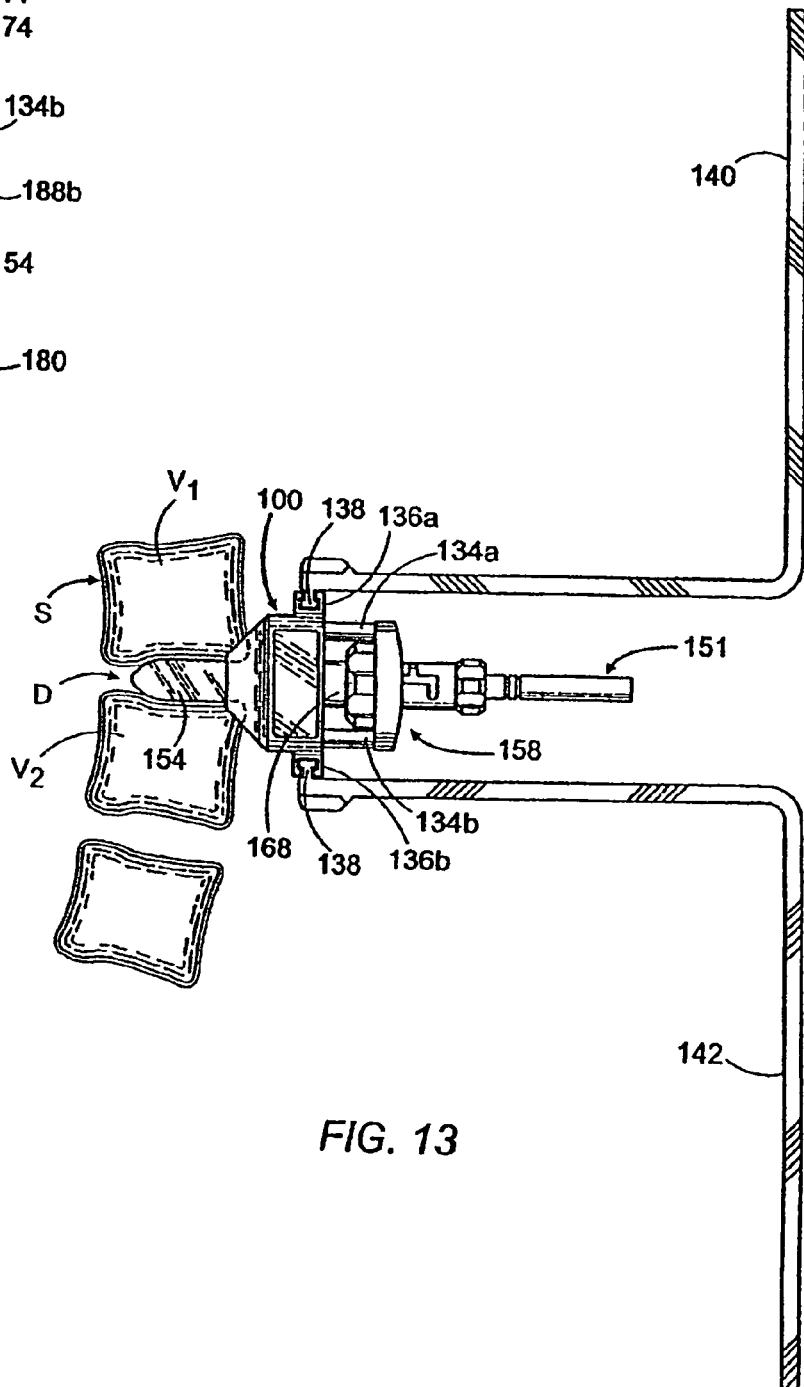

FIG. 13

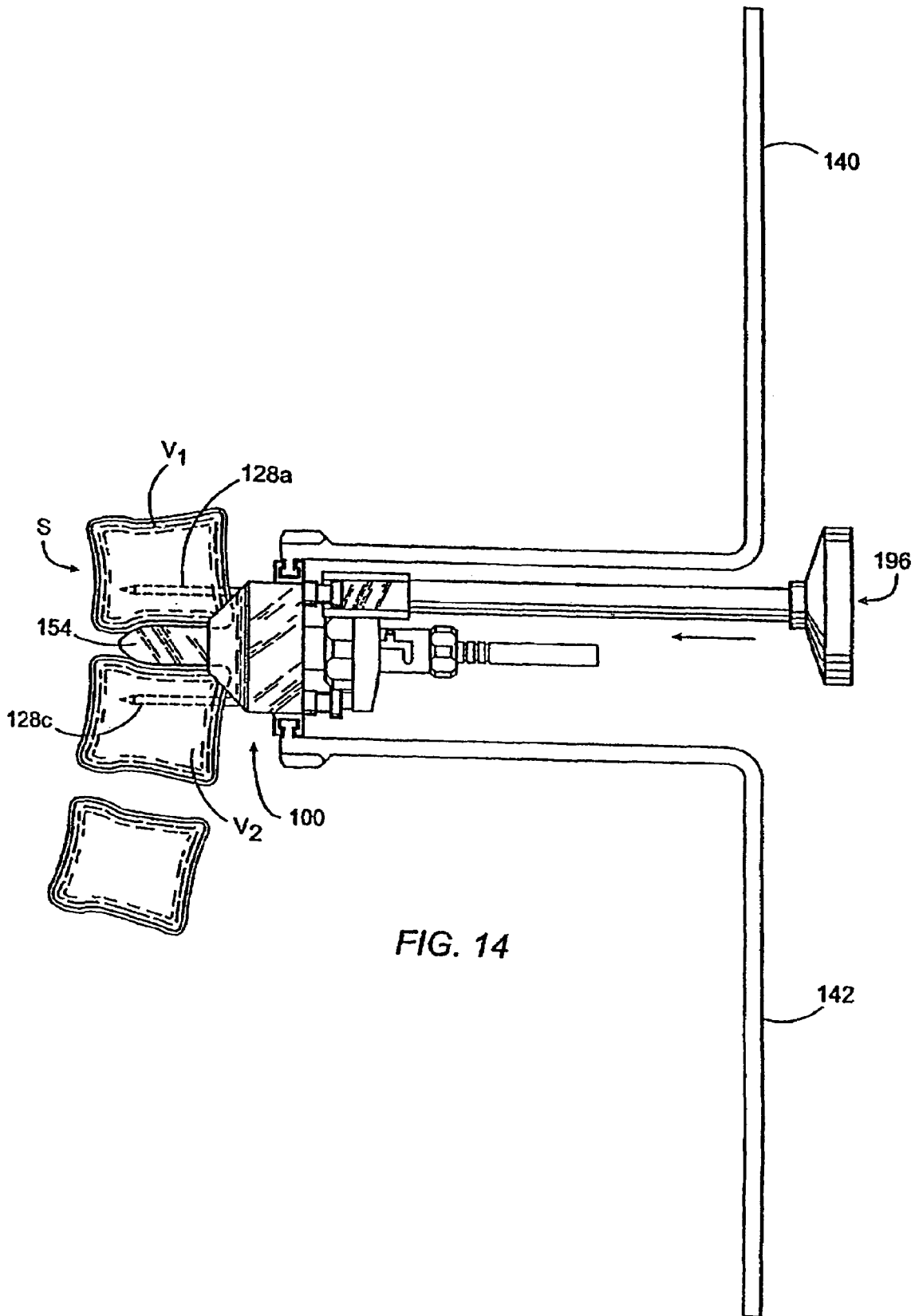
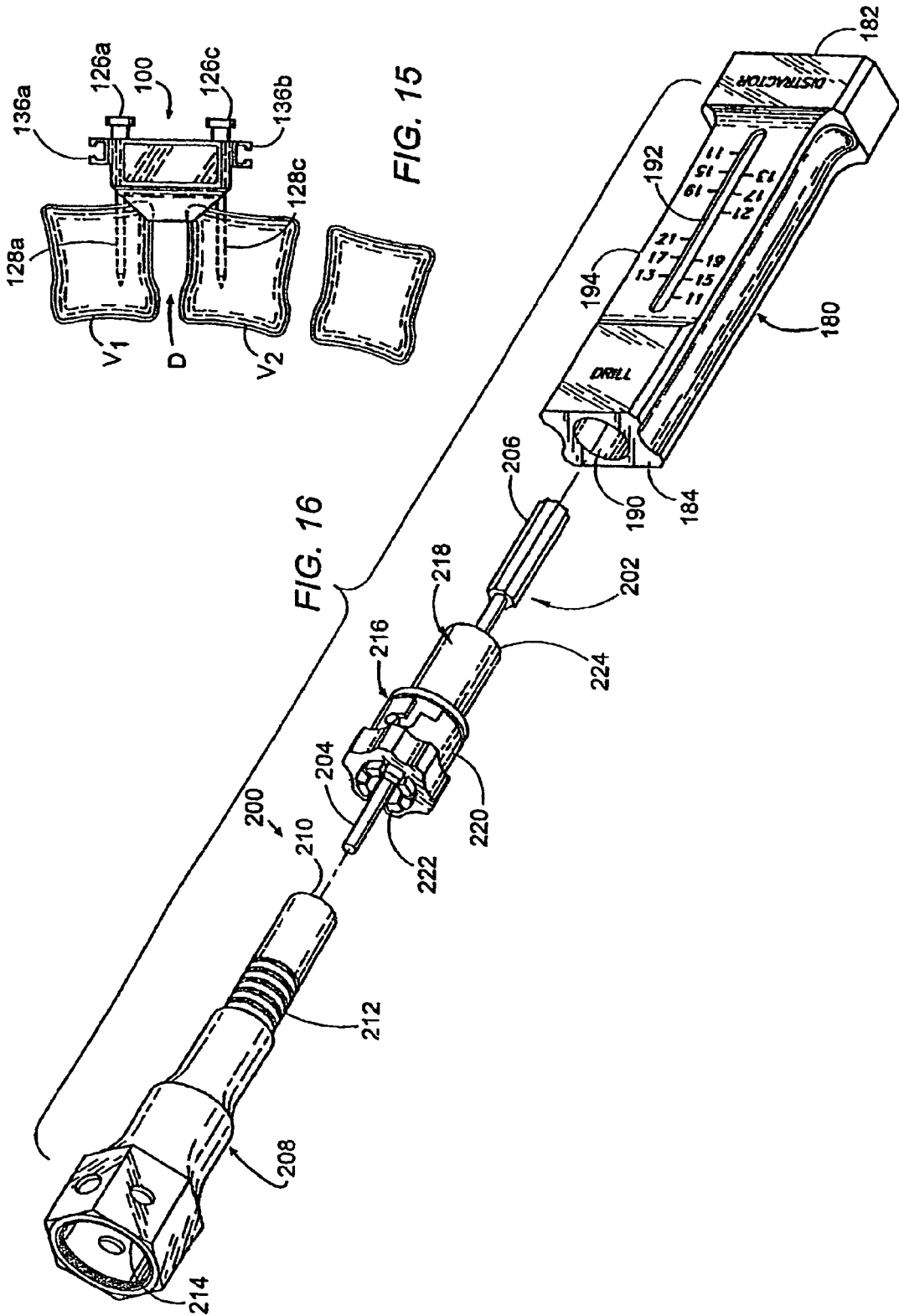

FIG. 14



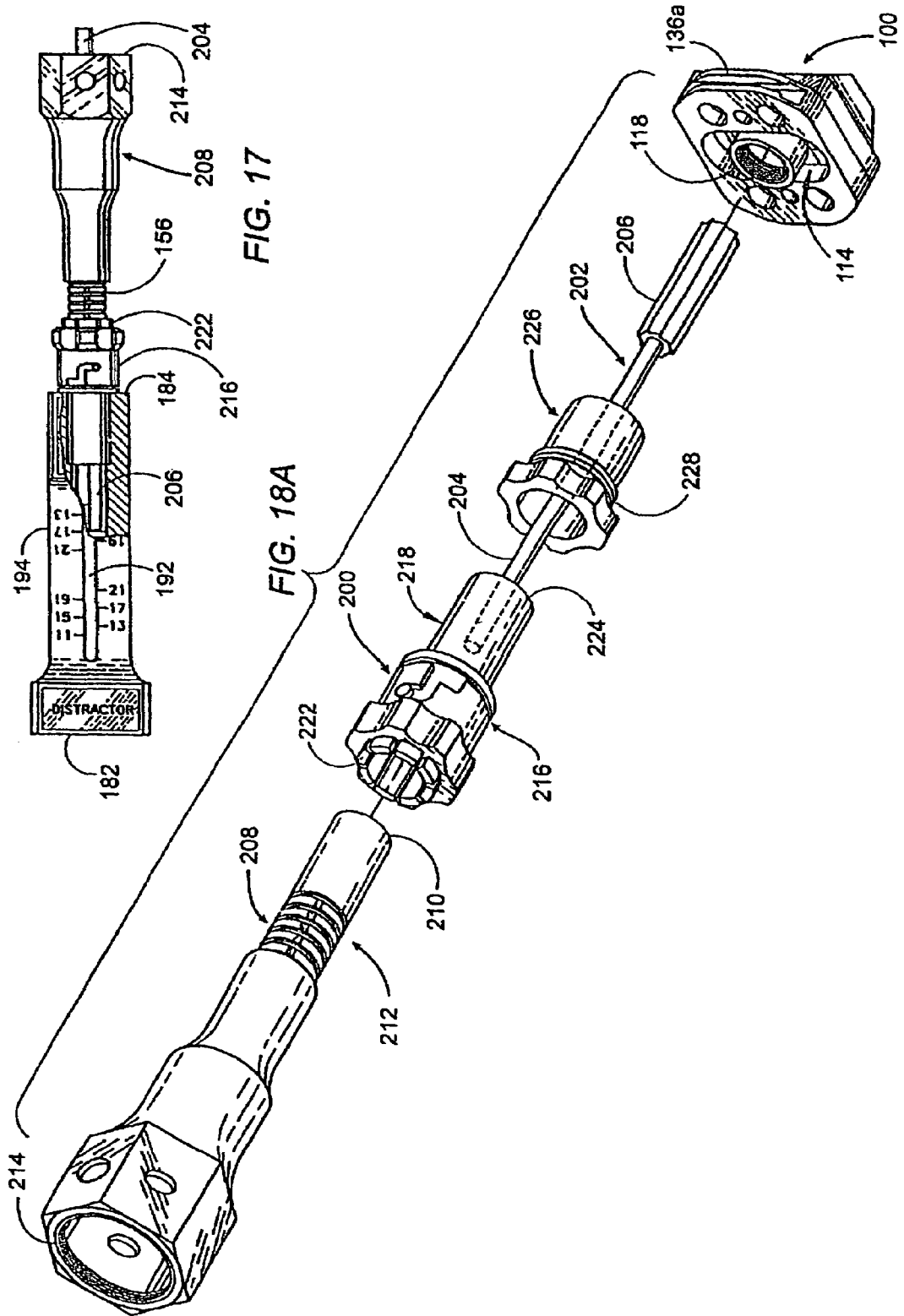
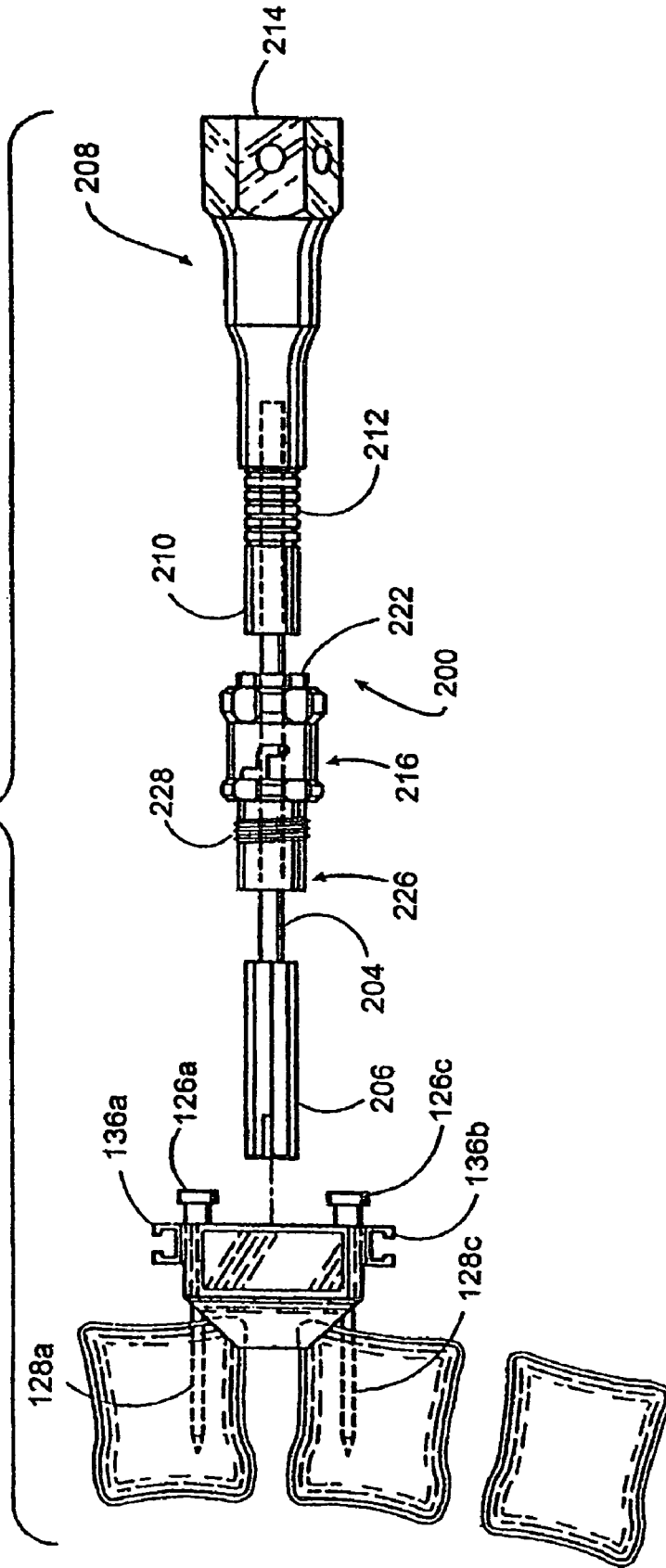

FIG. 17

FIG. 18A

100

FIG. 18B



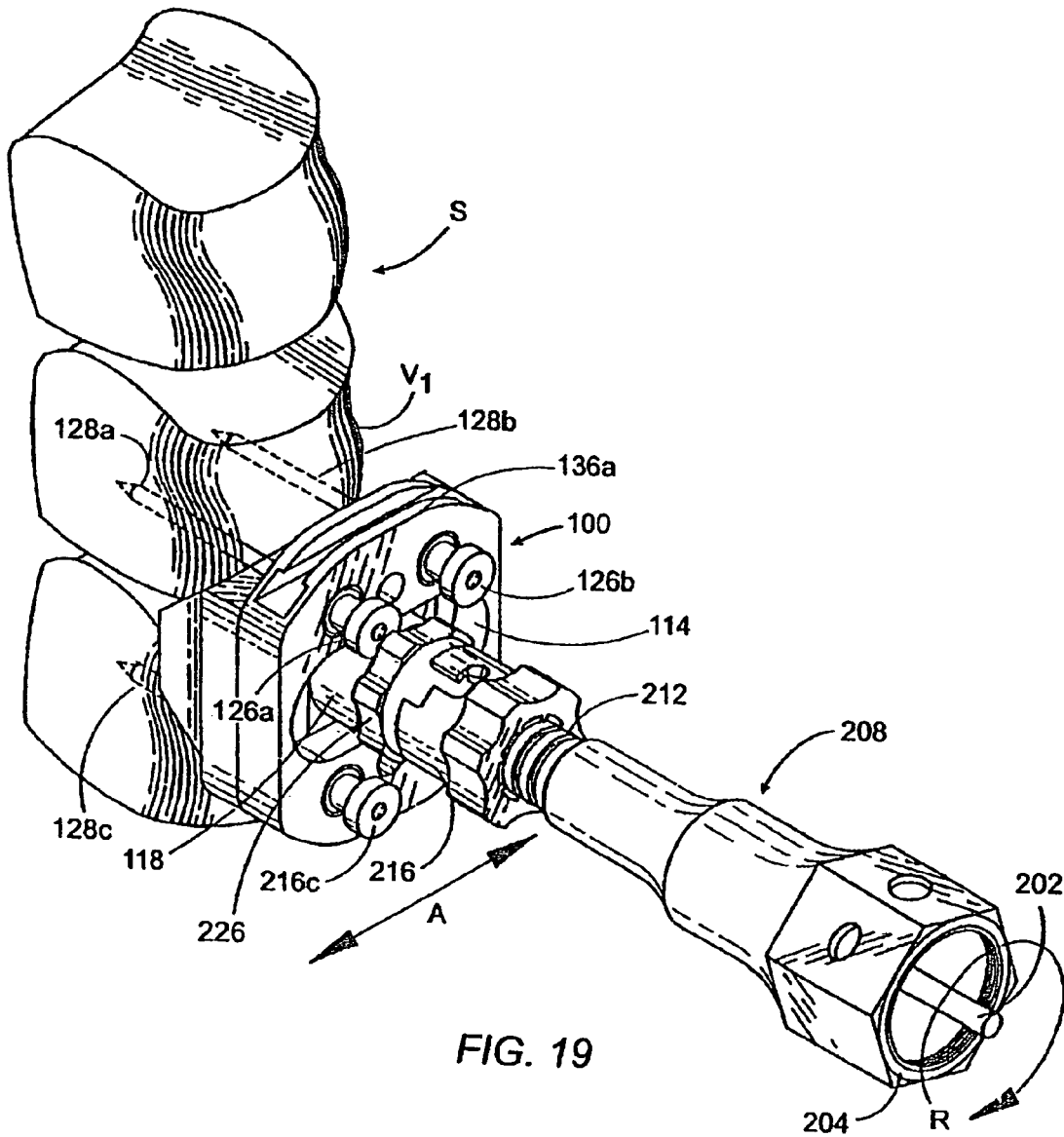

PRIOR ART

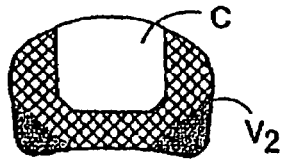

FIG. 26

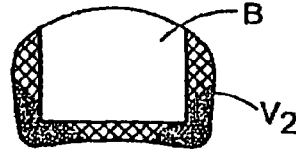

FIG. 22

PRIOR ART

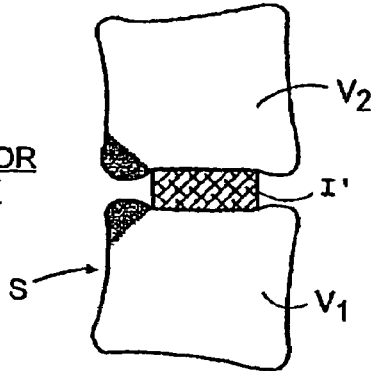

FIG. 24

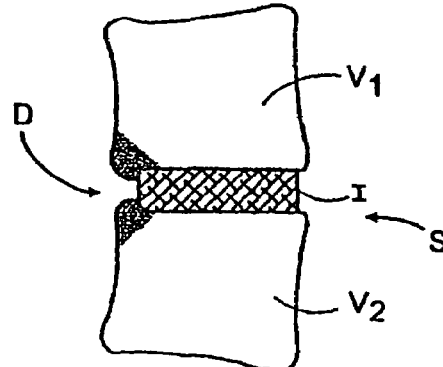

FIG. 20

PRIOR ART

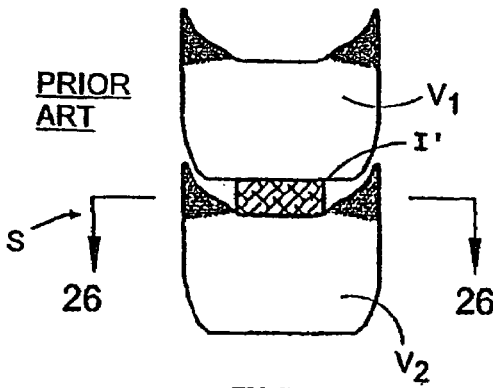

FIG. 25

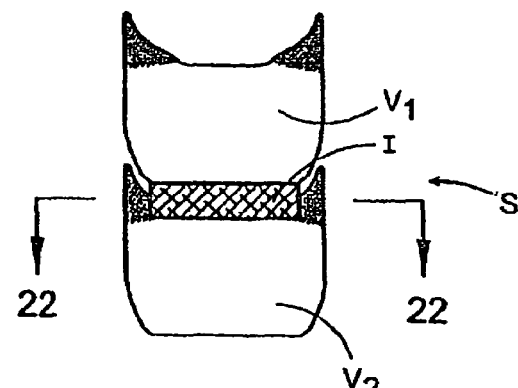

FIG. 21

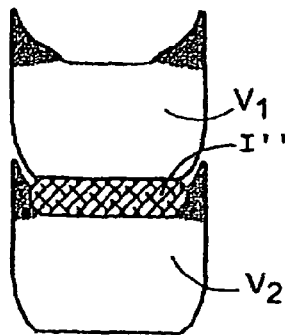

FIG. 23

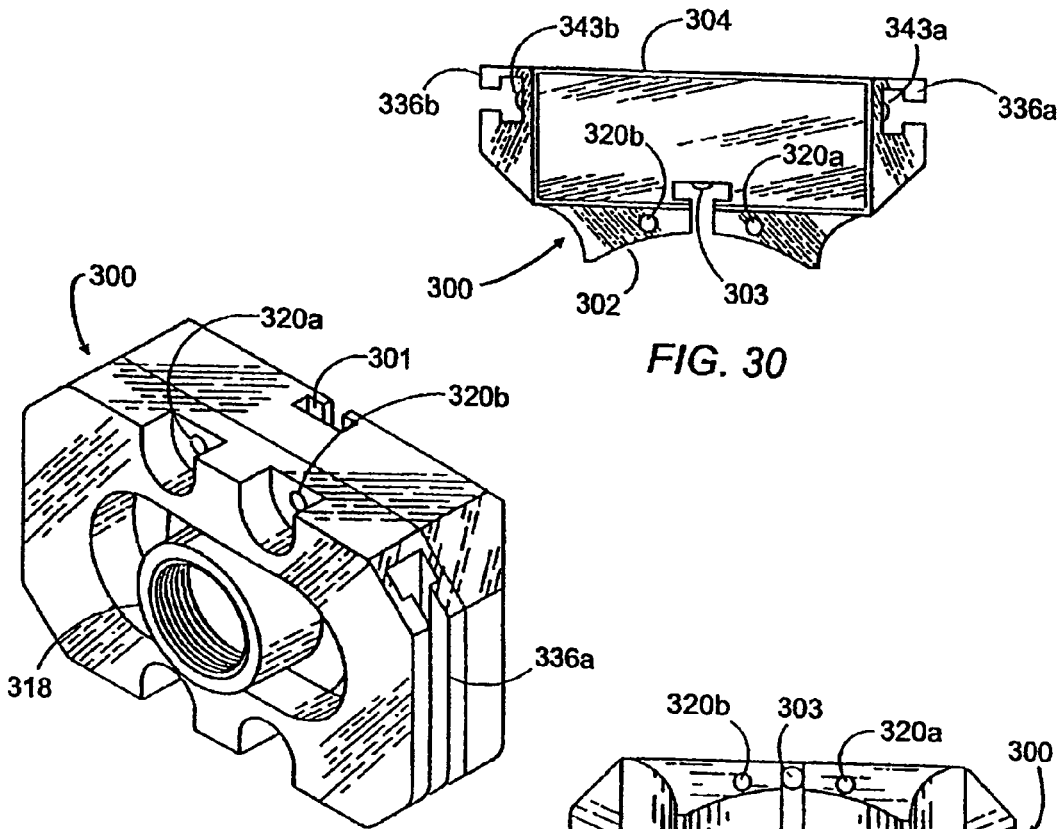

FIG. 27

FIG. 30

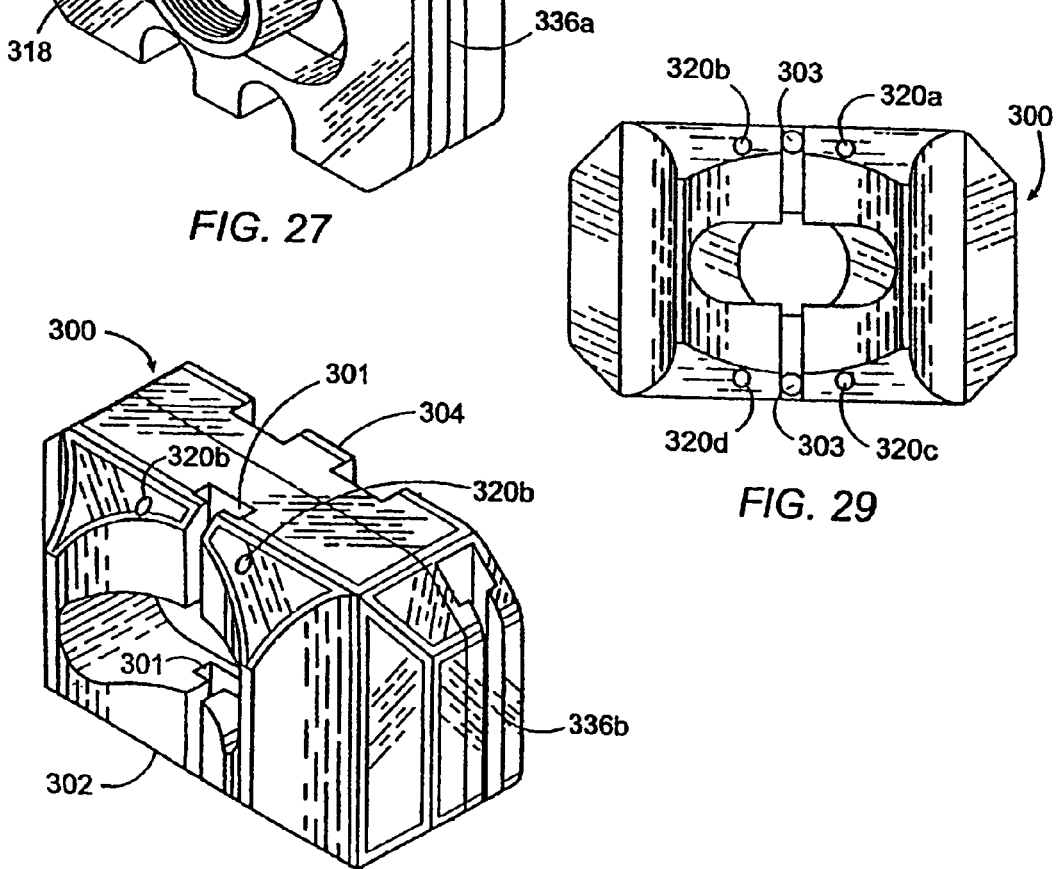

FIG. 28

FIG. 29

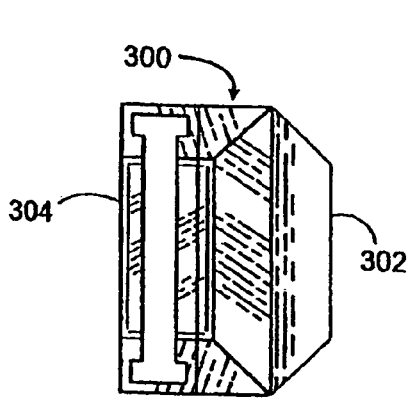

FIG. 31

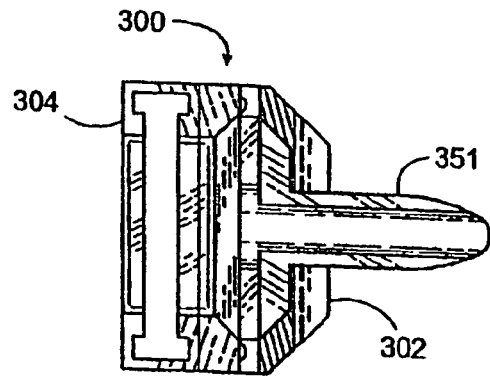

FIG. 32

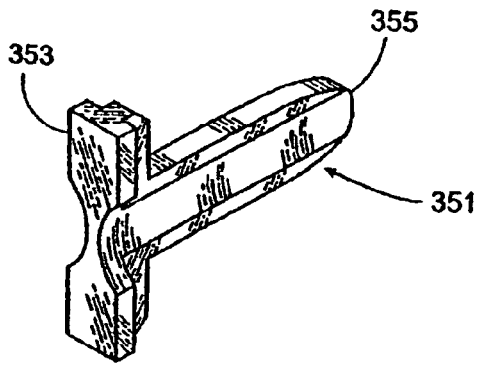

FIG. 33

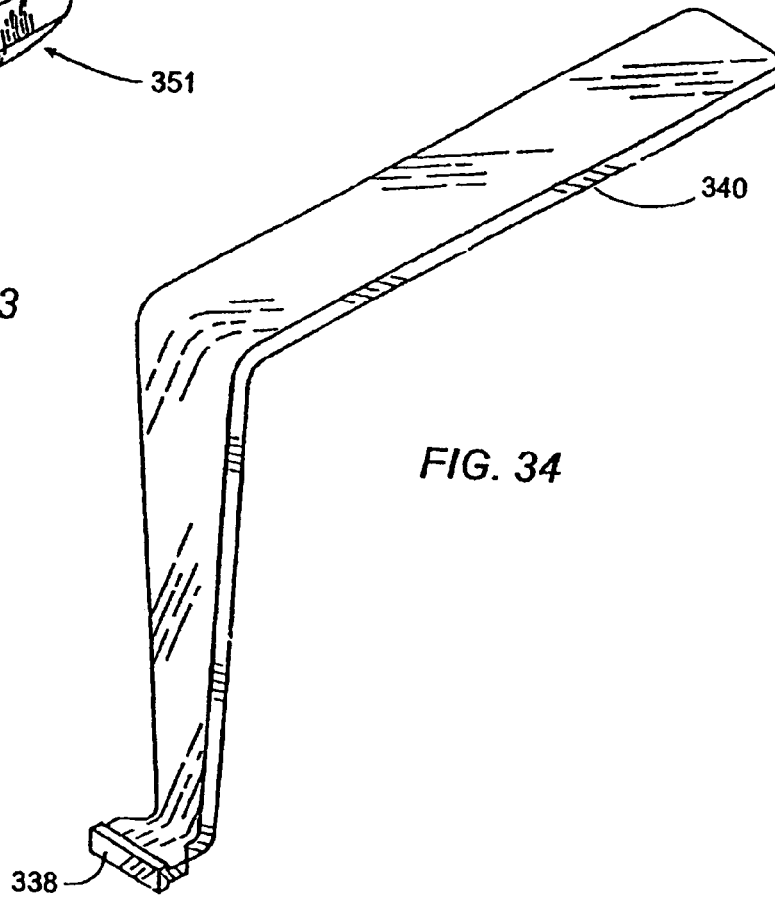

FIG. 34

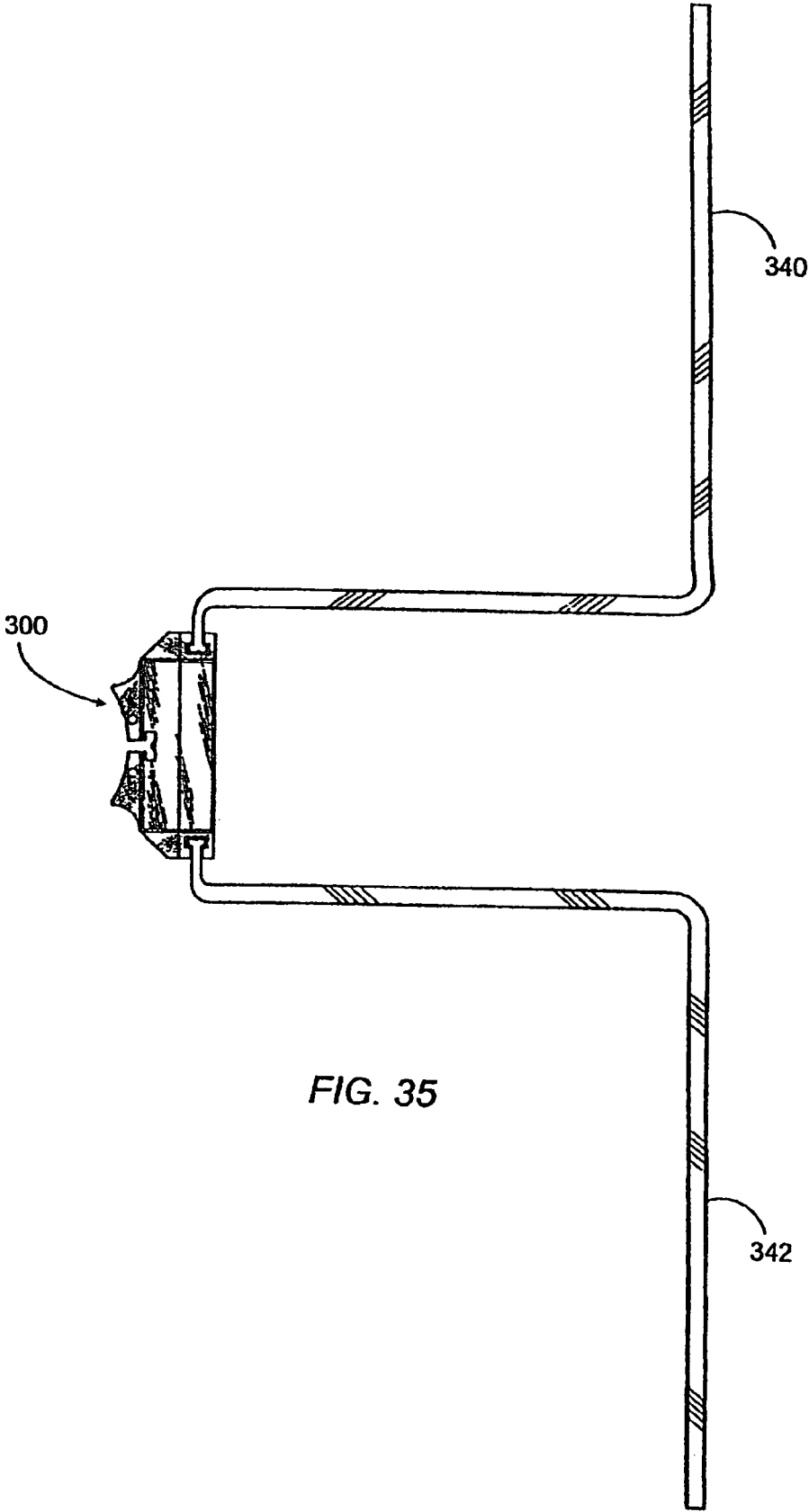
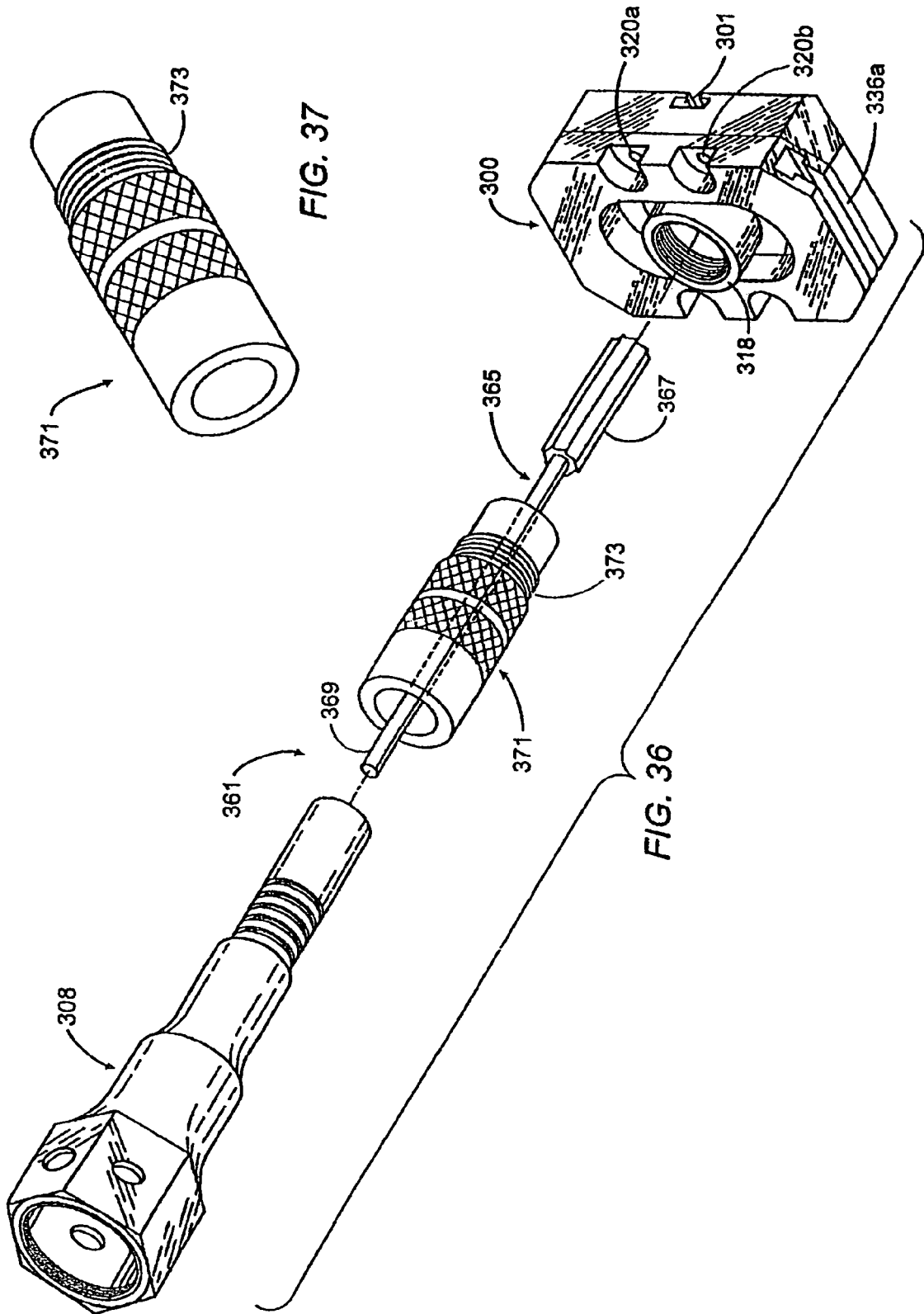

FIG. 35



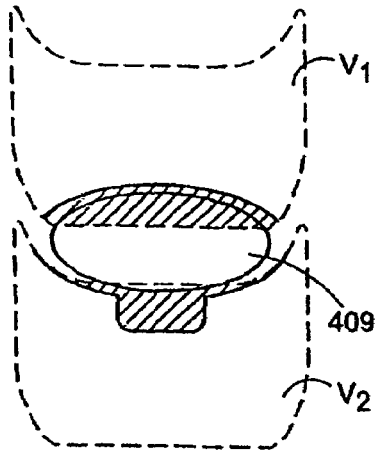

FIG. 45

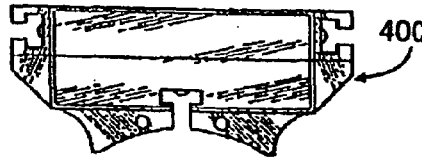

FIG. 40

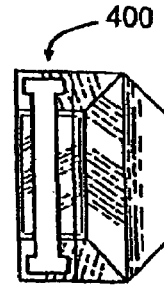

FIG. 41

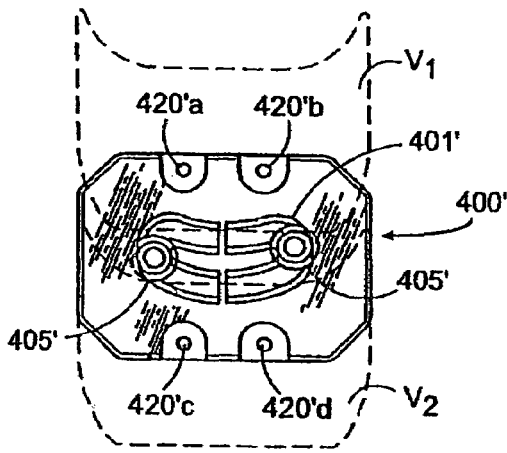

FIG. 43

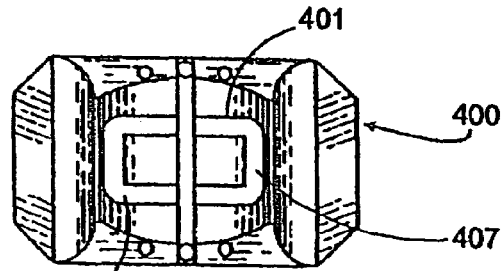

FIG. 38

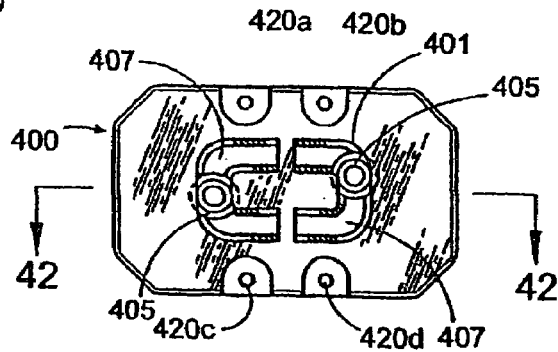

FIG. 39

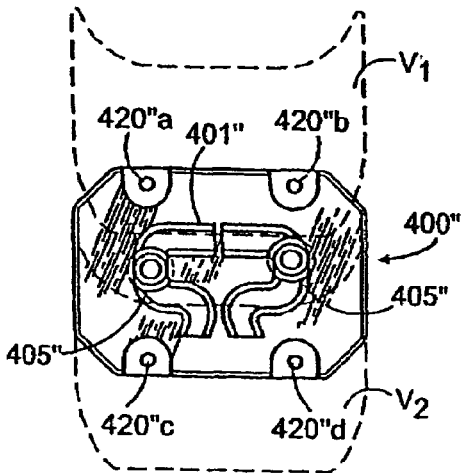

FIG. 44

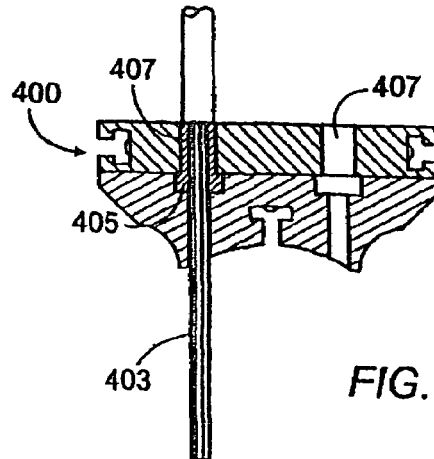

FIG. 42

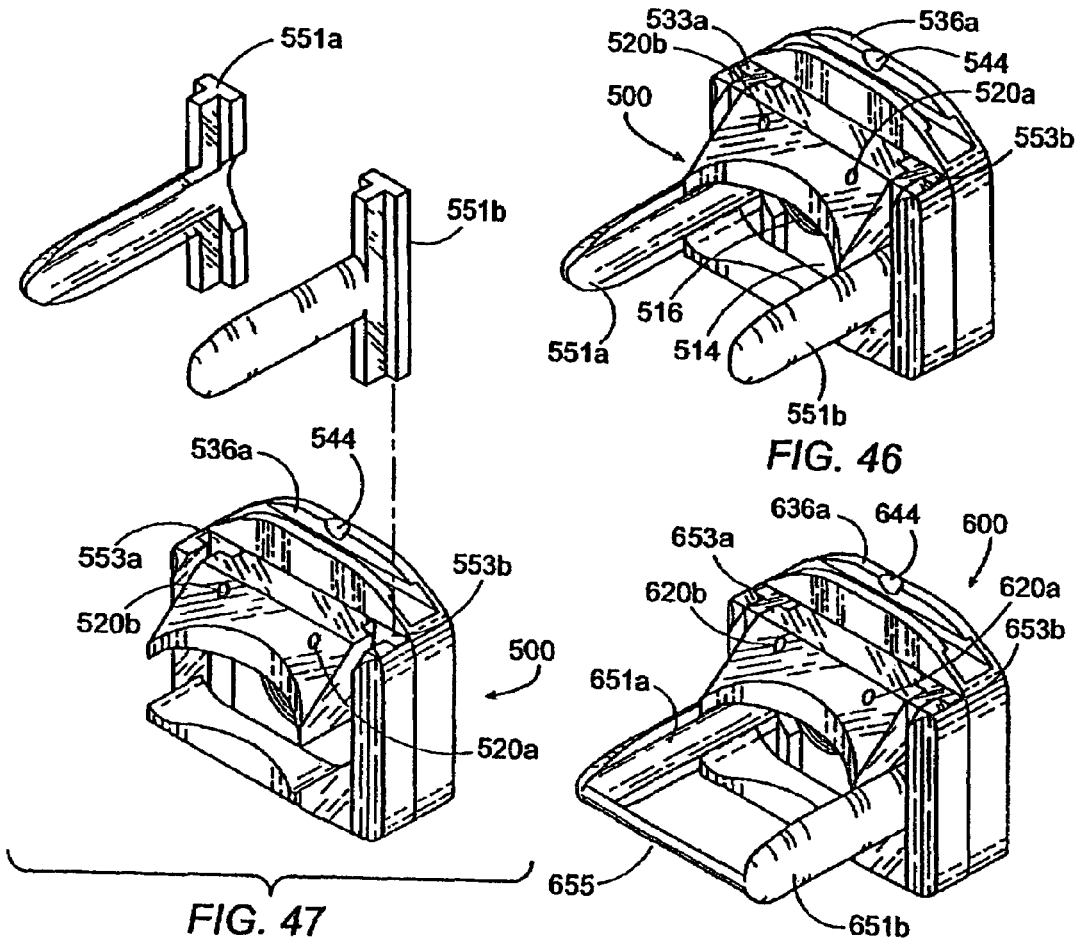

FIG. 47

FIG. 46

FIG. 48

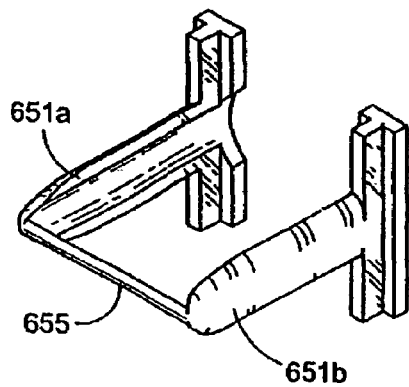

FIG. 49

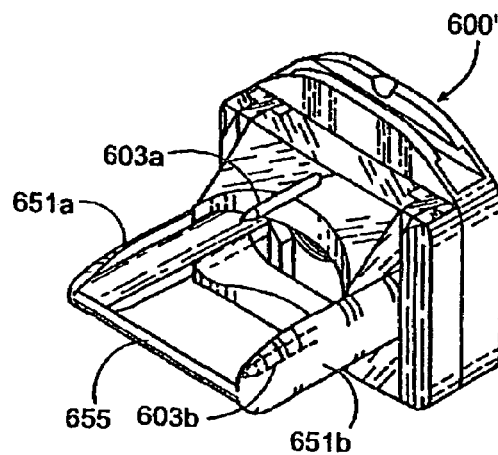
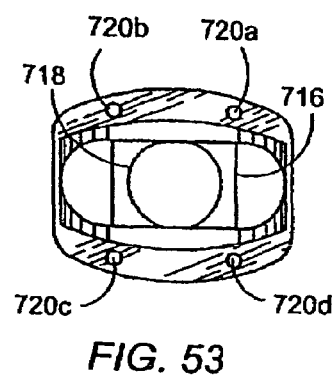
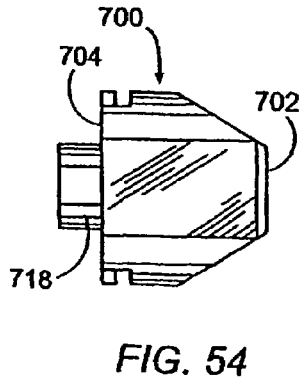
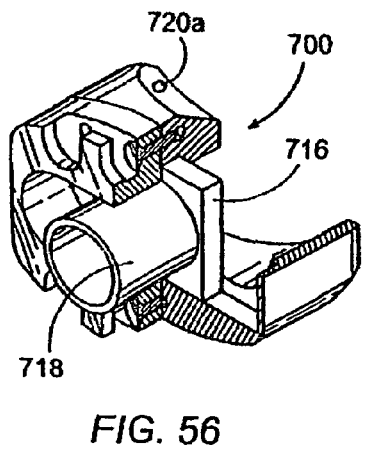
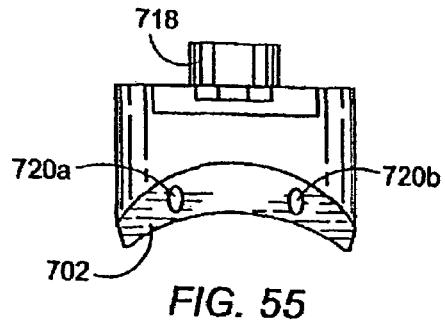
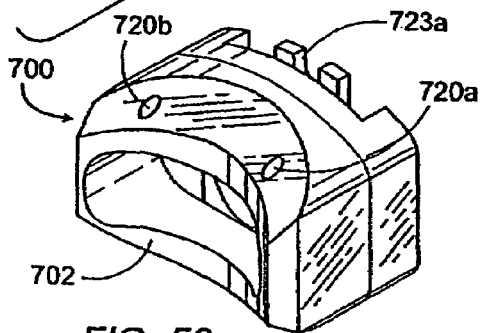
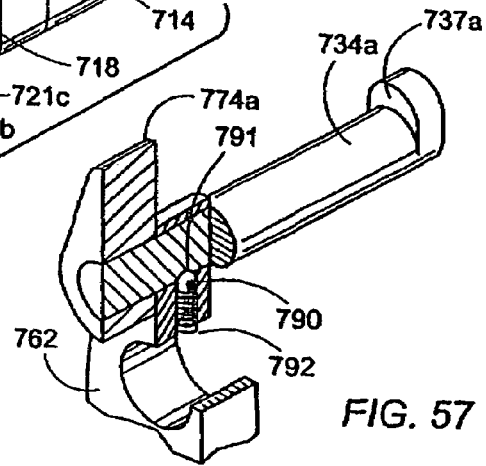
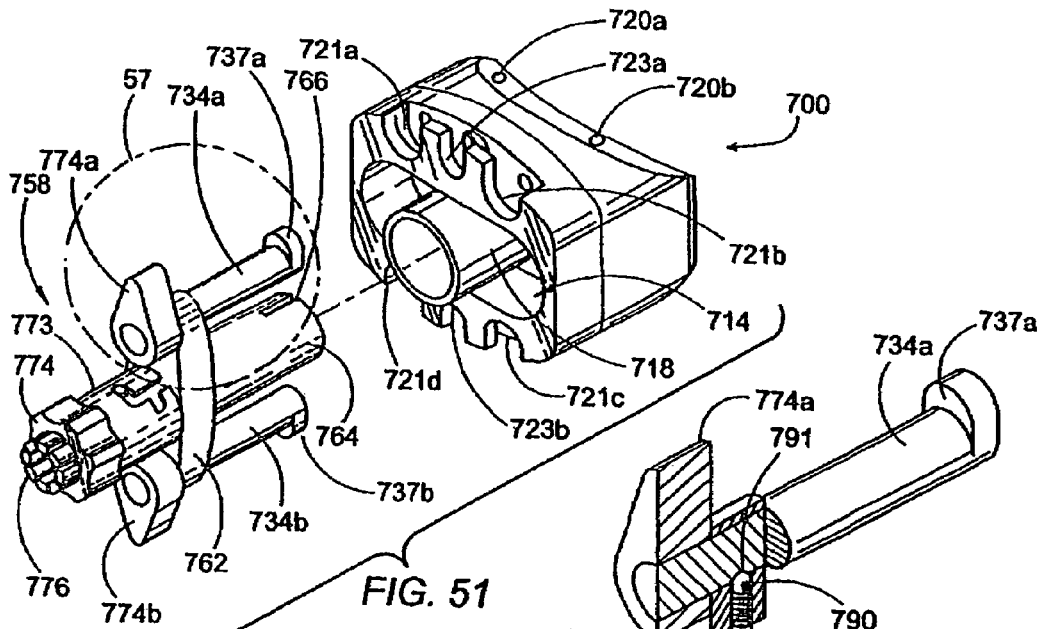

FIG. 50



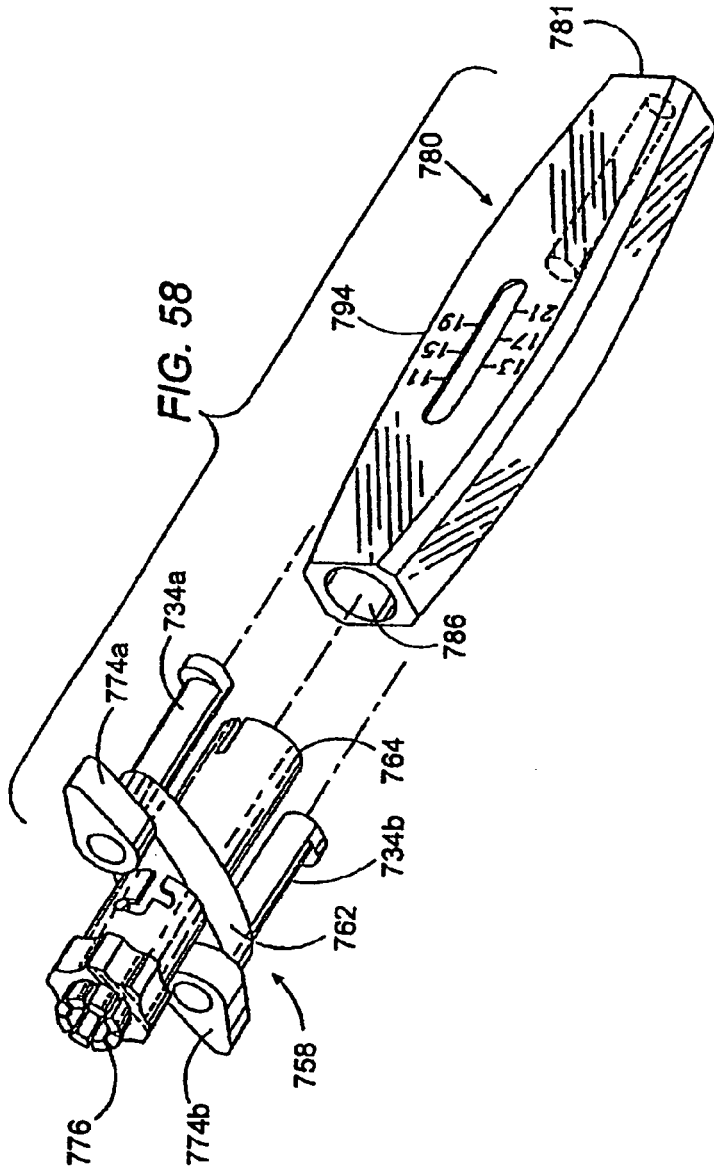

FIG. 58

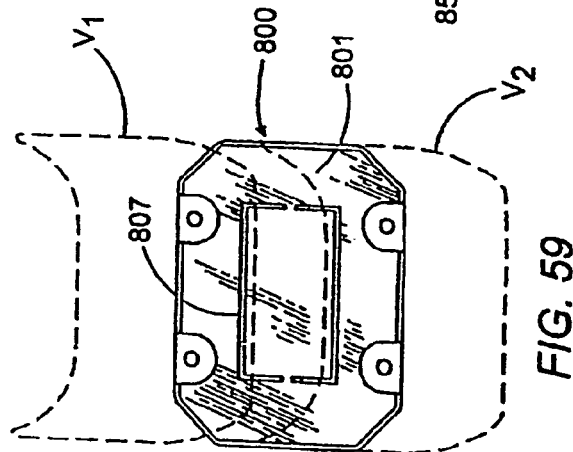

FIG. 59

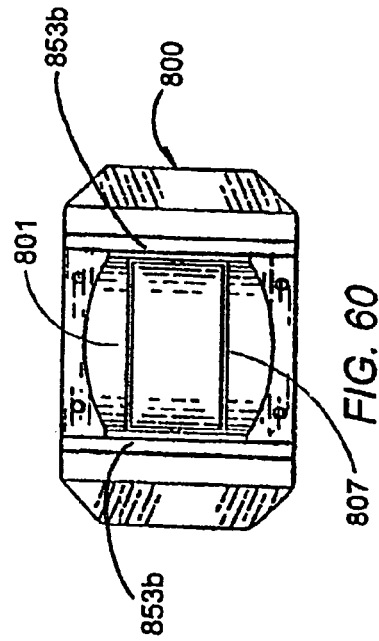

FIG. 60

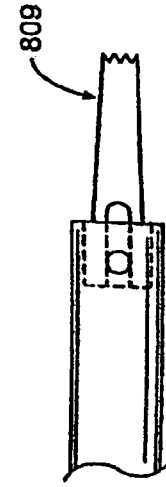
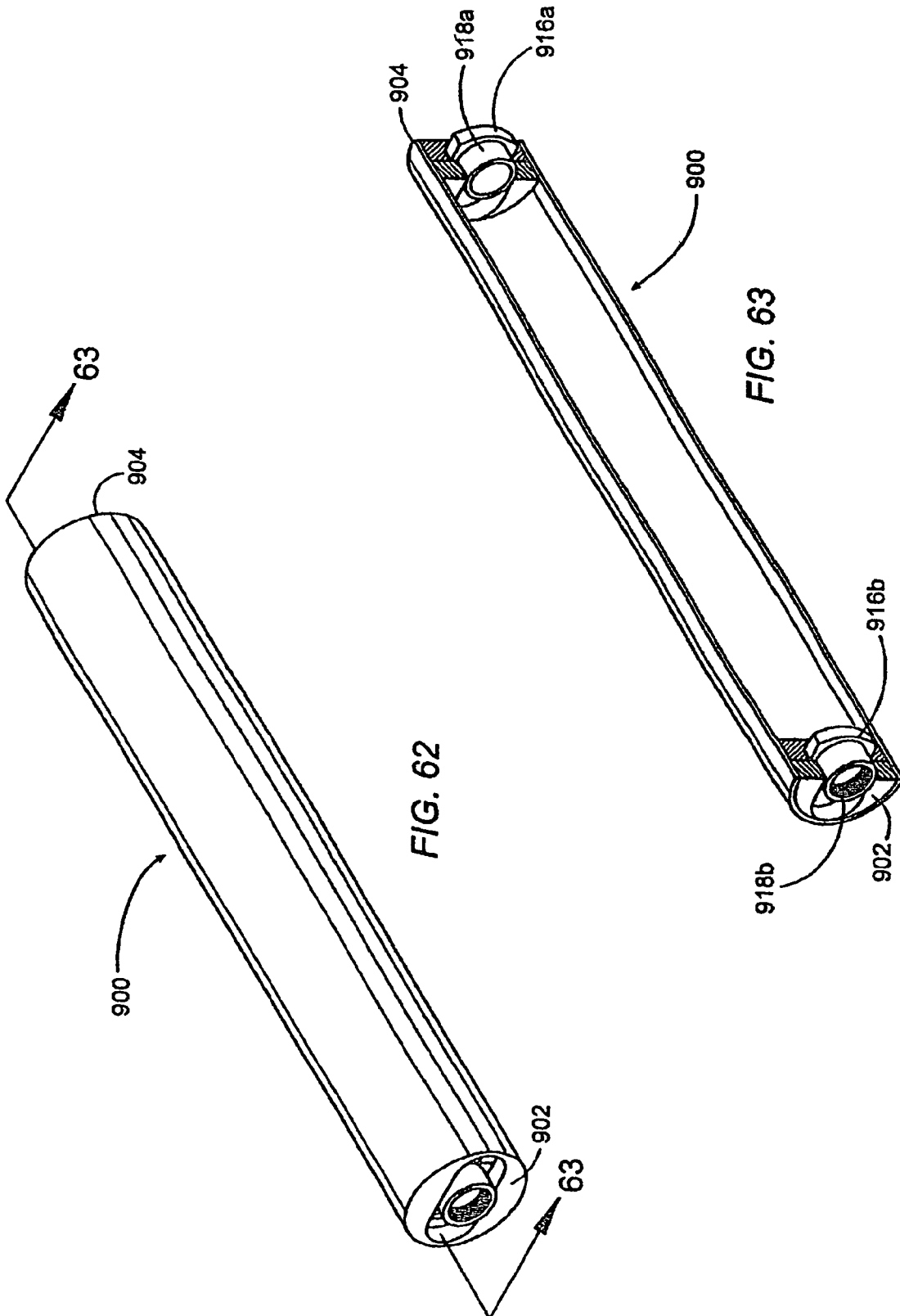

FIG. 61



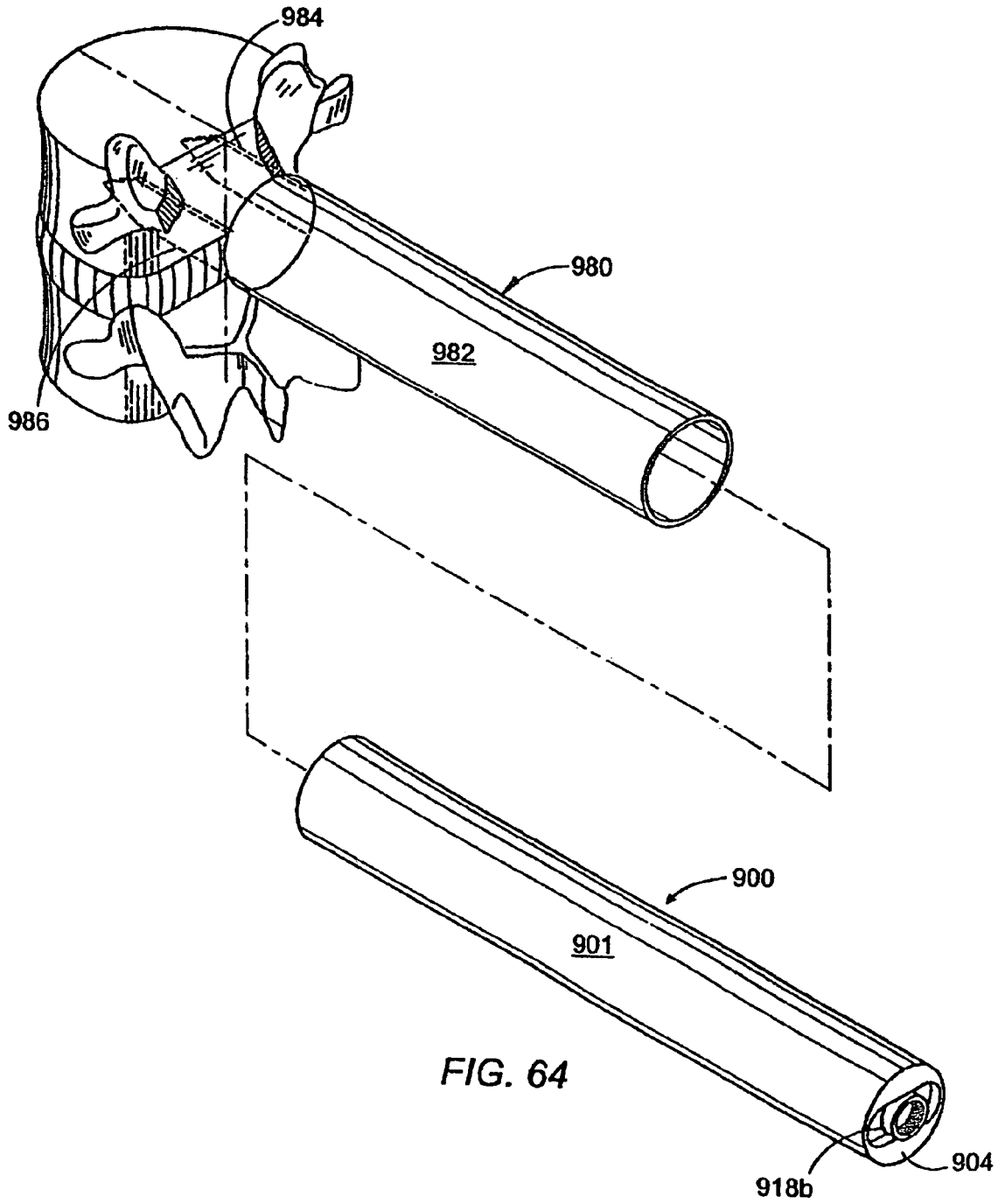

FIG. 64

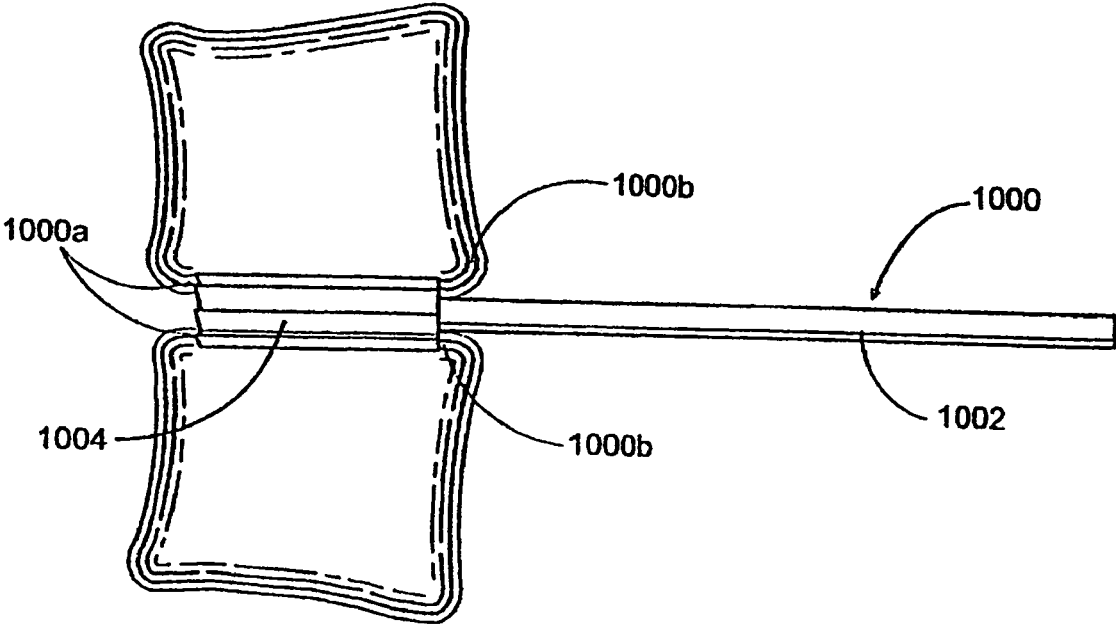
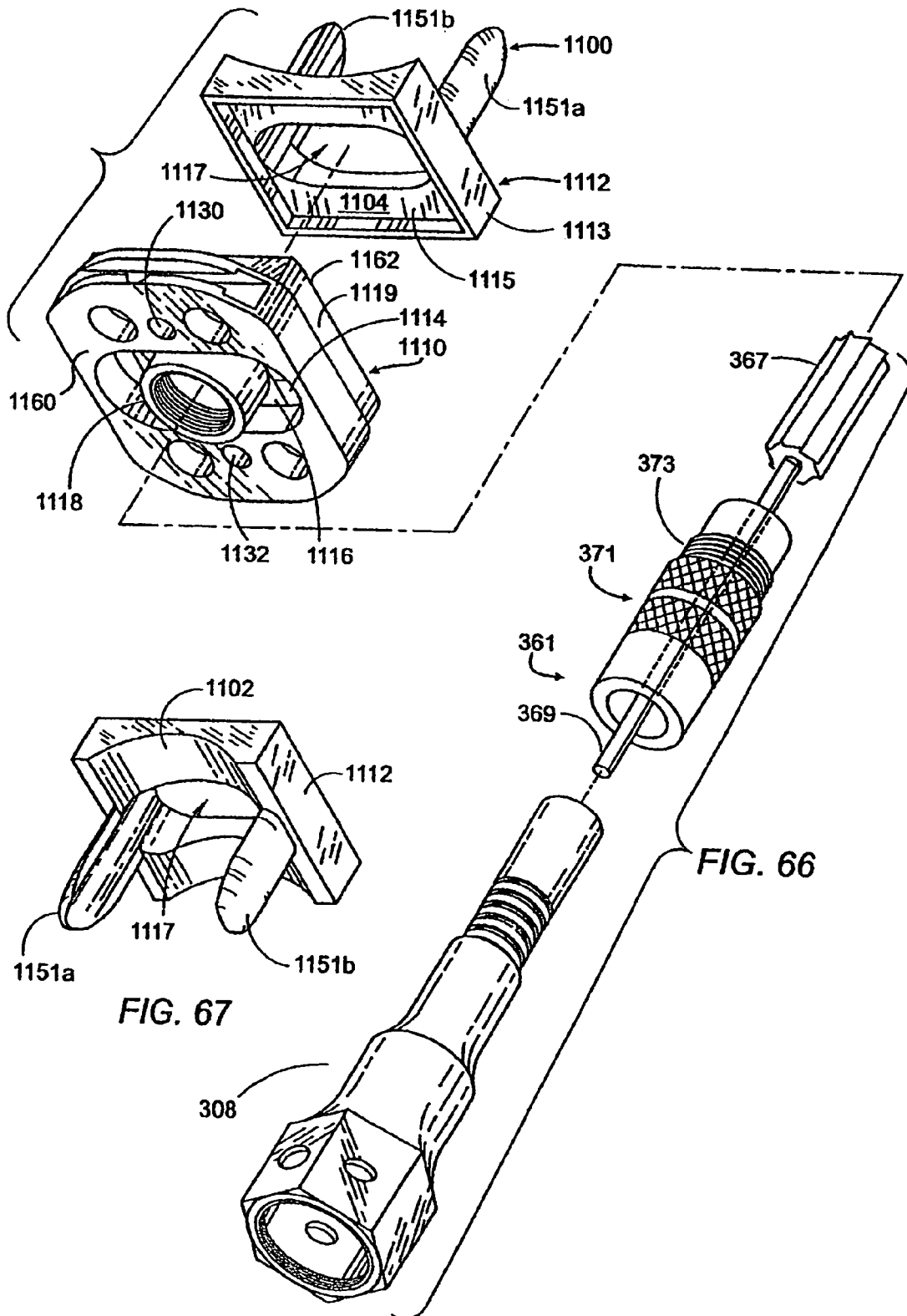

FIG. 65



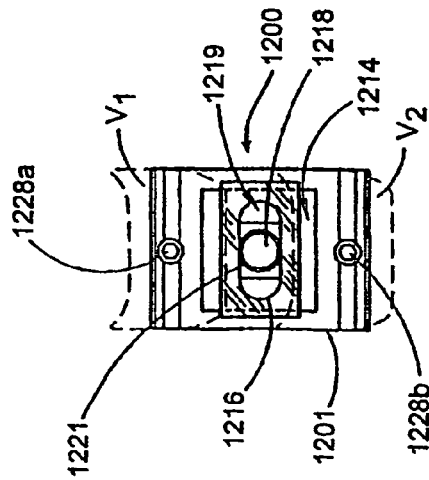
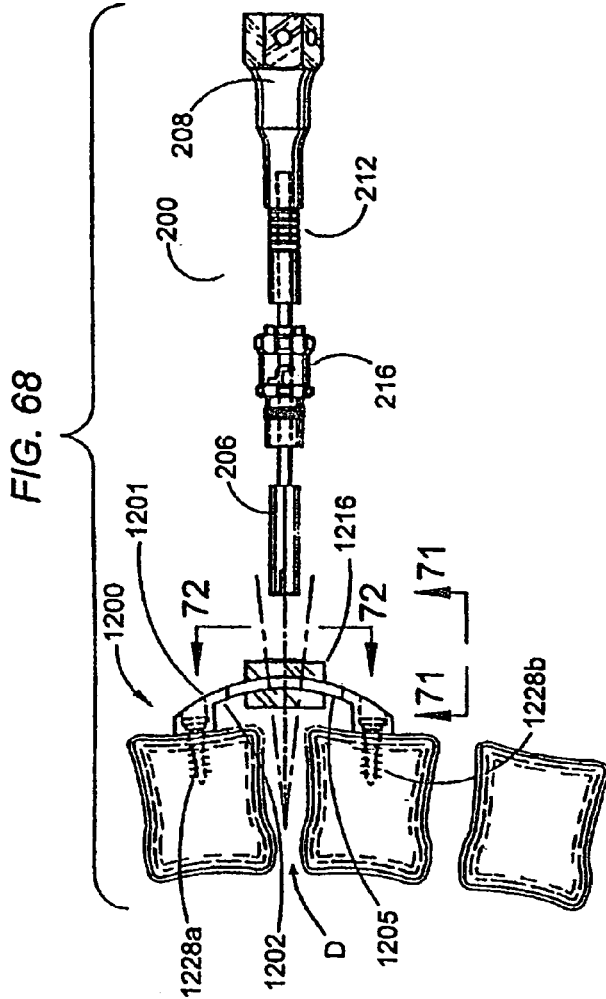

FIG. 69

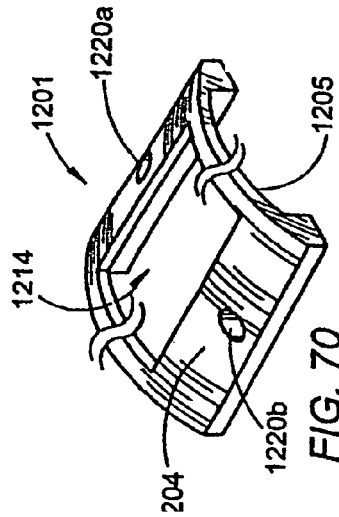

FIG. 70

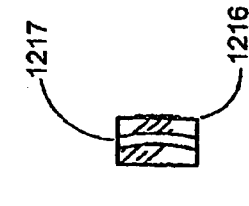

FIG. 71

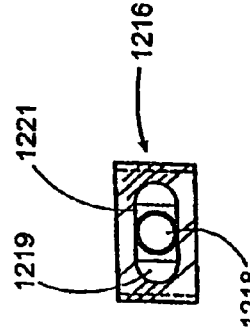

FIG. 72

BONE REMOVAL DEVICE

The present application is a continuation of Ser. No. 10/090,506, filed Feb. 27, 2002 now U.S. Pat. No. 7,083,623; which is a continuation of application Ser. No. 09/734,303, filed Dec. 12, 2000, now U.S. Pat. No. 6,440,139; which is a continuation of application Ser. No. 08/688,758, filed Jul. 31, 1996, now U.S. Pat. No. 6,159,214; all of which are incorporated herein by reference.

BACKGROUND OF THE INVENTION

Spinal fusion is defined as the joining together of two or more adjacent vertebrae through a bridge of bone for the purpose of eliminating motion between those vertebrae. One specific type of spinal fusion is known to those skilled in the art as interbody fusion and consists of fusing the adjacent vertebrae through the disc space (the space previously occupied by the spinal disc interposed between the adjacent vertebral bodies). When such a procedure is performed from the anterior aspect of the spine (from the front) that procedure is known as anterior interbody fusion.

Typically, bone grafts are placed into the disc space to position the vertebrae apart so as to create more space for the nerves, to restore the angular relationship between said adjacent vertebrae to be fused, and to provide for material that can participate in and promote the fusion process. Substrates, other than bone, such as hydroxyapatite and/or artificial spinal fusion implants may also be used.

In general the ability to achieve bone fusion appears to be related to certain metabolic biochemical factors, the quality and quantity of the osteogenic material present (bone forming material, most commonly bone itself), the surface area available for the fusion to occur over, and the stability of the construct being fused (the ability to resist unwanted motion at the fusion site).

Consistent with the foregoing, it is desirable for the surgeon to place the largest fusion implant, generally bone, within the disc space as this provides for both the greatest surface area, and fusion mass. Furthermore, the greater the area of contact, the greater the stability of the bone-graft construct, such, that the graft is less likely to migrate, to itself collapse, or conversely to penetrate into the adjacent vertebrae as the forces across the fusion site are distributed over a greater area.

The disc space can best be described as having a biological rather than a geometric shape in that the adjacent vertebral endplate surfaces are complexly biconcave in portions, convex in others, while in still other areas extremely dense portions of bone project like "pillars" almost perpendicularly from the plane of the vertebral endplates, thereby forming partial, but substantial, side walls about the posterolateral (toward the back and side) portions of the disc space, the latter being particularly pronounced in the cervical spine.

As the bone graft used for the purpose of interbody fusion must have sufficient structural integrity to support the superincumbent body weight and the forces present across the portion of the body in which the graft is inserted, generally only quite solid portions of bone can be used for this purpose. Such portions of bone can only be cut, such as with a saw, rather than molded to fit the disc space. Even for the most skilled surgeon, it is not possible to shape such grafts to precisely fit the complex contours of the vertebral endplates adjacent the disc space. Therefore, the bone grafts are generally considerably smaller in width and depth than the disc space itself so as to confine such grafts to the more relatively flat area located about the mid portion of the vertebral end-

plates. The term "relatively flat" is a correct description of the mid portion of the endplate in that even this region of the vertebral endplate is not truly flat, such that it is relatively rare to achieve full congruency between the machined surface of the bone graft and the biologically determined shape of the vertebral endplate. This further compromises the quality of the fusion construct in that the area of contact between the vertebrae and the graft is suboptimal with a loss of both support area and correspondingly, graft and construct stability.

Further factors tending to limit the dimensions of the graft to less than that of the disc space include, for example in the cervical spine, the danger of the graft accidentally escaping the disc space laterally (to the side), damaging the vertebral arteries and causing a cerebral infarct and the danger of penetrating posteriorly (toward the back) and injuring the spinal cord causing paralysis. Furthermore, the previously described pillars of dense bone projecting from the overall plane of the vertebral endplates in the posterolateral portions of the disc space and commonly known as either uncinete processes or the joints of Luschka, tend to block the lateral and posterior placement of the graft(s) and tend to confine and limit the placement of the graft(s) to the anterior and central portions of the disc space.

To achieve fusion, it is necessary to at least vigorously scrape the outermost layer of the vertebral endplates until bleeding occurs to encourage the fusion, which invokes a healing process of the bone. Since the vertebral endplates are generally quite strong, it is desirable to preserve this structure even while scraping into it which can not reliably be achieved by the means of the prior art. In the past, anterior interbody fusion would be performed by removing at least a portion of the intervertebral disc and then utilizing hand held, free-hand instruments including, but not limited to, osteotomes, chisels, curettes, rongeurs, and burrs to scrape and shape the vertebral endplates and vertebral bone stock, which operations would be performed generally by working on one vertebra at a time, and independent of the position of the adjacent vertebra.

As a final consideration, not only are the vertebral endplates complexly shaped, but so are the interposed discs themselves. That is, the vertebrae of the spine are generally aligned in curved, rather than straight patterns when viewed from the side. When such curves are convex forward, as they are in the cervical and lumbar spine, the vertebrae are said to be in lordosis. Such lordosis may be the result of wedging of the vertebral bodies, of the discs, or a combination of both. When lordosis is the result of a generally wedge shaped disc, it has generally proven difficult to reliably restore that overall wedged shape to the disc space itself for the purpose of fusing the adjacent vertebrae with precisely the correct amount of lordosis.

While the discussion above has been in regard to anterior interbody fusion, it may be desirable to replace a damaged or diseased disc with a flexible member, or mechanical "artificial disc", in which situation maximizing the surface area and congruency of contact, and controlling the angular and spatial relationships of the vertebrae adjacent that disc space would still be of great importance. As to be discussed, the present invention pertains to a means and method for the preparation of the space between adjacent vertebral bodies ("the disc space") suitable for the implantation of an artificial disc or for interbody spinal fusions.

Attempts have been made in the past to create a guided milling apparatus for use in surgery of such appendicular joints as that of the knee. For example, U.S. Pat. No. 5,486,180 issued to Dietz on Jan. 23, 1996 teaches the use of a guided milling apparatus. The Dietz apparatus is not capable

of working in the spine to prepare a space between adjacent vertebral bodies and differs from the present invention in the following ways:

- 1) The Dietz apparatus requires that the bone be exposed end on (Col. 1, lines 34-36, Col. 2, lines 46-47, FIGS. 1, 2, and 3). In the present invention, the "ends" of the vertebrae to be prepared are the vertebral endplates which can not be exposed on end except by dislocating the vertebrae which would cause the most grievous harm to the patient.
- 2) The Dietz apparatus is for the preparation of a single bone at a time (Col. 1, lines 34-36, Col. 1, lines 49-50; FIGS. 1, 2, 3, 5, 7).
- 3) The milling end of the Dietz apparatus removes the bone parallel to the template surface (Col. 4, lines 7-9, Col. 4, lines 50-53, FIGS. 5 and 7). In the spine, there is insufficient space available within the disc space interposed between adjacent vertebrae to insert, accommodate or operate the Dietz mechanism; this would be true regardless of actual size of the Dietz device for any size that would remain workable for use in the spine.
- 4) The Dietz apparatus is incapable of affixing the opposed bones on both sides of the joint simultaneously, or of preparing both joint surfaces with the opposed bones in fixed relationship with each other.
- 5) The Dietz apparatus teaches a means for cutting across two dimensions while controlling (fixing) for depth. (FIGS. 5,27).
- 6) Dietz teaches that the mill end is too large to pass through the template guide surface so as to confine the mill end beneath the guide means. (Col. 3, lines 8-19, Col. 4, lines 24-53; FIGS. 5 and 7). This thus requires that the enlarged burr portion enters the bone not through its end or face, but rather on the front surface of the bone, which entrance occurs through a cut out slot, is deep to the guide plate, and with the burr spinning about an axis parallel to the longitudinal axis of the bone itself. (Col. 2 Line, 35-37, FIGS. 1 and 2).
- 7) The Dietz apparatus is limited to the cutting by use of a burr along a nonlinear path. (Col. 2, lines 65; Col. 3, lines 4-6; Col. 4, line 2, FIGS. 4 and 6). This is not arbitrary as the path of the burr is guided by either or both of a pivot, allowing only for a series of arcs, and/or a branched and serpentine slot system also configured to produce only a series of arcs. (Col. 2, lines 41-42, line 52, line 65 through Col. 3, line 4, and FIGS. 1, 2, 4 and 26).

There is therefore a need for a method and means for preparing the vertebral bodies and the vertebral endplates adjacent to a disc space to be fused by interbody fusion that:

- 1) allows for the safe preparation of the disc space to the optimal depth and width so as to allow for the correct use of the largest possible fusion implant which would be associated with the direct benefits of providing for the maximum mass of osteogenic material, the largest possible surface area for fusion to occur over, increased graft and construct stability secondary to the increased area of contact, and the greatest protection against implant collapse or penetration into the vertebral bodies from the distribution of the loads over the greatest surface area;
- 2) allows for the preparation of the vertebral endplates to a known and uniform surface configuration, which configuration can be matched by a corresponding surface of the fusion implant thereby providing for the greatest possible interface congruity between the vertebral endplates and fusion implant, and providing for the optimal

contact surface, enhanced fusion area, enhanced graft and construct stability, and decreased load per surface area;

- 3) allows for the restoration of the correct vertebral alignment by preparing the vertebral endplates in fixed relationship to each other adjacent the disc space so as to three dimensionally shape the disc space-fusion implant site;
- 4) allows for an efficient and reliable means for scraping the central portions of the outer layer of the vertebral endplates without the danger of removing those structures entirely; and
- 5) allows for the extension of the fusion area into the extremely supportive and extremely dense bone of the posterior lateral regions of the disc space.

SUMMARY OF THE INVENTION

The present invention is directed to an apparatus and method for use in spinal surgery for creating a space of selected shape and dimensions across the disc space between two adjacent vertebrae of the spine. The present invention comprises an integrated system of instrumentation and a surgical method that is capable of placing the adjacent vertebrae to be operated upon in proper angular relationship to each other, of locking the vertebrae in that position, of simultaneously preparing both vertebral endplates for the procedure, be it fusion or disc replacement, and specifically the creation of a space of a known shape and dimensions. The foregoing is achieved by the use of a power milling apparatus such that all free hand motions are eliminated and the site size, shape, and configuration, as well as the extent of vertebral endplate resection are made predictable, precise and reproducible. The instrumentation of the present invention allows for the safe controlled and protected preparation of the disc space to the optimal depth and width. The present invention allows for implant(s) or bone grafts to be placed onto the area of dense bone at the posterior lateral aspects of the disc space. The present invention allows for the maximum stability of the graft/implant, as well as the construct, by providing for the greatest possible interface surface area and congruency between the graft/implant and each of the adjacent vertebrae.

The present invention further provides for increased stability by creating butted corners, posterolaterally, into which the graft/implant may be fitted which corners prevent further movement of the graft/implant either posteriorly or to either side of the created space. The present invention is capable of the uniform preparation (scraping) of the central portion of the vertebral endplate otherwise leaving that structure intact, if so desired. The present invention makes possible the preparation of the disc space to be prepared in anatomical angular conformation, and the disc space can be formed so as to correspond to the known shape of the graft/implant to be utilized.

In one embodiment, the apparatus of the present invention comprises a milling block having a front face configured for placement against a segment of the spine and having at least one aperture for accessing each of the two vertebral endplates of the vertebral adjacent the disc space. The adjacent vertebrae are placed in the appropriate spatial relationship to each other with a distractor means. Instrumentation is disclosed for selecting and calibrating the maximum safe penetration depth of the distractor means into the disc space and for locking the selected depth to prevent unwanted over penetration into the disc space. The distractor means may be part of the milling block or may be a separate member that is coupled to the milling block either directly or by a distractor holder.

5

Associated with the milling block is a bone removal means for removing a portion of bone from each of the vertebral endplates adjacent the disc space. The bone removal means is capable of accessing the vertebral endplates through the aperture in the milling block. The milling block is held firmly against a segment of the spine by securing means, such as prongs, pins, screws and the like, or by the distractor means itself inserted into the disc space in contact with the endplates of the adjacent vertebrae. Instrumentation is disclosed for selecting, calibrating and limiting the penetration depth of the bone removal means into the disc space and/or vertebrae and to prevent unwanted over penetration into the disc space and/or vertebrae. The bone removal means may be guided with an instrument guiding means located in the aperture of the milling block and in slideable relation to the milling block permitting slideable transverse motion and/or vertical motion during operation of the bone removal means to remove a portion of bone from the vertebral endplates adjacent to the disc space.

The following is a brief outline of the steps of the surgical method of the present invention describing the use of the specific instrumentation in regard to the preferred embodiment:

1. The area of the spine to be fused is exposed and a partial disectomy is performed, whereby a portion and preferably a large portion of the disc is removed while preserving the annulus fibrosis portion of the disc along at least both sides of the disc space.
2. The interspace so created is distracted and while not requisite, preferably to its optimal height, which height is determined by the known normal spatial relationships for that area the adjacent soft tissue structures. The interspace is then measured for height, depth, and width. The width of the interspace may be determined in reference to the inferior portion of the vertebral endplate of the superior vertebrae, and this determines the selection of the appropriate width for the milling block. The measured depth of the interspace, that is the distance between the front and back of vertebrae, will determine the selection of a distractor and milling means of slightly lesser depth. The height and depth of the interspace will determine the selection of the appropriate height and length of the distractor element, the shape of which is determined by both the need to either maintain or restore lordosis, as well as the shape of the implant which may or may not be wedged.
3. The correct distractor element is selected, having either a known fixed length, or preferably is adjustable and its optimal fixed length adjusted using a calibration gauge, integral markings or similar means.
4. The distractor apparatus is then attached to the milling block which has already been selected for the correct width.
5. The combined distractor apparatus and milling block assembly is then brought to the fusion site and the distractor element is introduced into the disc space. The distractor element may be introduced into the disc space turned on its side so as to facilitate introduction and then turned 90 degrees to distract the space or the distractor element may be introduced perpendicular to the plane of the disc space relying on its bullet-shaped leading edge portion to distract the vertebrae apart. The angular relationship of the two vertebral bodies adjacent that disc space will then be determined by the shape of the distractor element. It is appreciated that while not preferred, a distractor could be inserted into the disc space

6

- first, then the milling block assembly is brought into place relative to the spine thereafter.
6. The milling block is then secured to the anterior aspect of the spine preferably, by engaging each of the adjacent vertebrae.
 7. The width and depth of bone resection may then be easily confirmed visually prior to any actual bone resection.
 8. The distractor element and distractor apparatus are removed from the disc space.
 9. The proper dimensioned bone removal means, corresponding to the previously employed distractor element, is selected and using the receiving depth gauge, the bone removal means is adjusted for depth and locked.
 10. The bone removal means is secured to the milling port of the milling block, and the space is then milled to remove a portion of bone from the endplates adjacent to the disc space.
 11. The milling apparatus is removed and the prepared space may be irrigated and suctioned through the milling block, or alternatively the entire milling assembly including the milling block may first be removed and the prepared space then irrigated and suctioned.
 12. The prepared space is distracted utilizing conventional means and the appropriate implant or implants are then inserted into the prepared space.

In the alternative, the surgical method of the present invention may be performed by utilizing a separable milling block having a separable member with bilateral, lateral distractor elements such that the distractor elements are left in place in the disc space while steps 9-12 above of the method are performed. However, in this instance no distraction would be necessary in step 12 as the distractor elements remain in place while the appropriate implant(s) are inserted into the prepared space and the distractor elements are subsequently removed. The placement of bilateral distractor elements also provides a safety means for preventing the bone removal means and implant from exiting from the sides of the disc space and out of the spine.

OBJECTS OF THE PRESENT INVENTION

It is an object of the present invention to provide for a surgical method and instrument means for performing interbody spinal fusion or in the alternative of inserting an "artificial disc implant" for the purpose of maximizing the width and optimizing the depth of the disc and the bone removed from front to back, or back to front, from the vertebral endplates adjacent the disc space to be fused or implanted while confining such bone resection safely within the lateral, anterior (front) and posterior (back) limits of the disc space.

It is another object of the present invention to provide for a surgical method and instrument means for performing interbody spinal fusion or "artificial disc" implantation that provides for the rapid creation of both a known surface contour of each of the vertebral endplates adjacent a disc space as well as a known and reproducible shape of the fusion or implantation site itself.

It is another object of the present invention to provide for a surgical method and instrument means for performing interbody spinal fusion that allows for the utilization of a larger interbody spinal fusion implant(s) than was possible with the prior art, such an implant having the capacity for providing increased amounts of osteogenic material, increased surface area, increased area of contact, increased stability and the ability to provide for greater support through the fusion area.

It is another object of the present invention to provide for a surgical method and instrumentation for performing the

preparation of the space between adjacent vertebrae for the purpose of implanting an artificial disc or fusion implant(s) having the optimal cross sectional area of contact with said adjacent vertebrae and where said cross sectional area may be as large as possible while remaining safely within the perimeter of the endplates of the adjacent vertebrae.

These and other objects of the present invention will become apparent from a review of the accompanying drawings and the detailed description of the drawings.

BRIEF DESCRIPTION OF THE DRAWINGS

FIG. 1 is a front perspective view of the milling block of the present invention.

FIG. 2 is a rear perspective view of the milling block of the present invention.

FIG. 3 is a front elevation view of the milling block of the present invention.

FIG. 4 is a top plan view of the milling block of the present invention.

FIG. 5 is a side elevational view of the milling block of the present invention.

FIG. 6 is a partial sectional view of the milling block of the present invention showing the sliding instrument guide within the milling block.

FIG. 7A is a side perspective view of a pin driving instrument and a pin used to secure the milling block of the present invention to a segment of the spine.

FIG. 7B is a top plan view of a pin used to secure the milling block of the present invention to the vertebrae.

FIG. 8 is a front perspective view of a handle used to hold the milling block of the present invention.

FIG. 9 is an exploded view of a distractor and distractor holder of the present invention with the distractor shown about to be inserted into the milling block of the present invention.

FIG. 10 is an exploded perspective view of the distractor holder of the present invention.

FIG. 11A is an exploded view of the distractor holder, the distractor and the calibration gauge of the present invention.

FIG. 11B is a side elevational view of the distractor of the present invention having an insertion end for placing two adjacent vertebrae in parallel relationship to each other.

FIG. 11C is a side elevational view of the distractor of the present invention having a converging insertion end for placing two adjacent vertebrae in angular relationship to each other such as lordosis.

FIG. 11D is a side elevational view of a segment of the spine with two distractors of the present invention placed at two adjacent disc levels illustrating the creation of lordosis with one distractor and the parallel spacing of the vertebrae by the other distractor.

FIG. 12 is a partial cut away of a front elevational view of the calibration gauge of the present invention with the distractor inserted therein and the distractor holder coupled to the distractor insertion end of the calibration gauge.

FIG. 13 is a side elevational view of the milling block of the present invention placed against the anterior aspect of a segment of the spine with the distractor holder coupled to the milling block and the distractor inserted in the disc space between two adjacent vertebrae and the handles attached to the milling block of the present invention.

FIG. 14 is a side elevational view of the segment of the spine with the milling block of the present invention attached to the anterior aspect of the spine by a plurality of pins shown partially in hidden line and being driven by a pin driver.

FIG. 15 is a side elevational view of a segment of the spine with the milling block of the present invention engaged to two adjacent vertebrae by a plurality of pins shown partially in hidden line.

FIG. 16 is an exploded perspective view of the bone removal assembly and calibration gauge of the present invention.

FIG. 17 is a partial cut-away of a front elevational view of the calibration gauge of the present invention with the bone removal assembly inserted therein to adjust the depth of the milling bit.

FIG. 18A is an exploded perspective view of the bone removal assembly of the present invention about to be inserted into the milling block of the present invention.

FIG. 18B is an exploded side elevational view of the bone removal assembly being inserted into the milling block of the present invention shown engaged to a segment of the spinal column.

FIG. 19 is a side perspective view of the bone removal assembly coupled to a milling block of the present invention that is engaged to a segment of the spinal column by a plurality of pins shown partially in hidden line.

FIG. 20 is a side elevational view of a segment of the spinal column having an implant inserted in the space created across the disc space and into the adjacent vertebrae with the milling block instrumentation and method of the present invention.

FIG. 21 is a front elevational view of a segment of the spine having an implant with flat side walls from top to bottom inserted in the space created across the disc space and into the adjacent vertebrae with the milling block instrumentation and method of the present invention.

FIG. 22 is a sectional view of a vertebra taken along line 22-22 of FIG. 21 illustrating the space created into the vertebrae by the milling block instrumentation and method of the present invention.

FIG. 23 is a front elevational view of a segment of the spinal column having an implant with curved side walls from top to bottom inserted into the space created across the disc space and into the adjacent vertebrae by the milling block and instrumentation of the present invention.

FIG. 24 is a side elevational view of a segment of the spinal column showing an implant inserted between two adjacent vertebrae with the methods and instrumentation of the prior art.

FIG. 25 is a front elevational view an implant inserted between two adjacent vertebrae with the methods and instrumentation of the prior art.

FIG. 26 is a sectional view along lines 26-26 of FIG. 25 illustrating the space created in the vertebrae by the methods and instrumentation of the prior art.

FIG. 27 is a rear perspective view of an alternative embodiment of the milling block of the present invention.

FIG. 28 is a front perspective view of the alternative embodiment of the milling block of the present invention shown in FIG. 27.

FIG. 29 is a front elevational view of the alternative embodiment of the milling block of the present invention shown in FIG. 27.

FIG. 30 is a top plan view of an alternative embodiment of the alternative embodiment of the milling block of the present invention shown in FIG. 27.

FIG. 31 is a side elevational view of the alternative embodiment of the milling block of the present invention shown in FIG. 27.

FIG. 32 is a side sectional view of the alternative embodiment of the milling block of the present invention shown in FIG. 27 with a distractor element inserted into the milling block.

FIG. 33 is a side perspective view of the alternative embodiment of the distractor element of the milling block of the present invention.

FIG. 34 is a side perspective view of an alternative embodiment of the handle used to hold the milling block of the present invention.

FIG. 35 is a side elevational view of the alternative embodiment of the milling block of FIG. 27 with a pair of detachable handles shown attached to the milling block.

FIG. 36 is an exploded perspective view of an alternative embodiment of the bone removal assembly and the milling block of the present invention shown in FIG. 27.

FIG. 37 is a perspective view of the adapter sleeve of the bone removal assembly of the present invention shown in FIG. 36.

FIG. 38 is a front elevational view of an alternative embodiment of the milling block of the present invention.

FIG. 39 is a rear elevational view of the alternative embodiment of the milling block of the present invention shown in FIG. 38.

FIG. 40 is a top plan view of the alternative embodiment of the milling block of the present invention shown in FIG. 38.

FIG. 41 is a side elevational view of the alternative embodiment of the milling block of the present invention shown in FIG. 38.

FIG. 42 is a sectional view along lines 42-42 of FIG. 39 of the milling block of the present invention having a bone removal member inserted therein for milling a space between two adjacent vertebrae.

FIG. 43 is a rear elevational view of an alternative embodiment of the milling block of the present invention with two adjacent vertebrae shown in hidden line.

FIG. 44 is a rear elevational view of an alternative embodiment of the milling block of the present invention with two adjacent vertebrae shown in hidden line.

FIG. 45 is an anterior elevational view of a segment of the spinal column illustrating the space created with the milling block of FIG. 44 and an artificial disc implanted within the created space.

FIG. 46 is a front perspective view of an alternative embodiment of the milling block of the present invention with a pair of distractor elements in place.

FIG. 47 is a front perspective exploded view of the alternative embodiment of the milling block of FIG. 46 and a pair of distractor elements of the present invention.

FIG. 48 is a front perspective view of an alternative embodiment of the milling block of the present invention.

FIG. 49 is a side perspective view of a pair of distractor elements of the present invention shown joined together at their tips.

FIG. 50 is a front perspective view of an alternative embodiment of the milling block of the present invention.

FIG. 51 is an exploded rear perspective view of an alternative embodiment of the milling block and distractor holder of the present invention for use in the cervical spine.

FIG. 52 is a front perspective view of the embodiment of the milling block shown in FIG. 51.

FIG. 53 is a front elevational view of the embodiment of the milling block shown in FIG. 51.

FIG. 54 is a side elevational view of the embodiment of the milling block shown in FIG. 51.

FIG. 55 is a top plan view of the embodiment of the milling block shown in FIG. 51.

FIG. 56 is a rear perspective fragmentary view of the embodiment of the milling block shown in FIG. 51.

FIG. 57 is a fragmentary view of the distractor holder along line 57 of FIG. 51.

FIG. 58 is a side perspective view of an embodiment of a combined calibration gauge and handle of the present invention.

FIG. 59 is a rear elevational view of an alternative embodiment of the milling block of the present invention with two adjacent vertebrae shown in hidden line.

FIG. 60 is a front elevational view of the alternative embodiment of the milling block shown in FIG. 59.

FIG. 61 is a side elevational view of a cutting instrument for use with the alternative embodiment of the milling block apparatus shown in FIG. 59.

FIG. 62 is a side perspective view of an alternative embodiment of the milling block apparatus of the present invention.

FIG. 63 is a sectional view along line 63-63 of FIG. 62 of the milling block apparatus of the present invention.

FIG. 64 is an exploded perspective view of a combined outer sleeve and distractor engaging two adjacent vertebrae and the milling block of FIG. 62 about to be inserted into the outer sleeve.

FIG. 65 is a side elevational view of the segment of the human spine with a milling instrument interposed between two adjacent vertebrae for preparing a disc space having anterior and posterior retaining walls for retaining an implant.

FIG. 66 is an exploded rear perspective view of an alternative embodiment of the milling block and bone removal assembly of the present invention.

FIG. 67 is a front perspective view of the distractor portion of the milling block of FIG. 66.

FIG. 68 is a side elevational view of an alternative embodiment of the milling block and bone removal assembly of the present invention shown engaging two adjacent vertebrae.

FIG. 69 is a rear elevational view of the milling block of FIG. 68.

FIG. 70 is a rear perspective view of the milling block of FIG. 68.

FIG. 71 is an elevational view along lines 71-71 of FIG. 68.

FIG. 72 is an elevational view along lines 72-72 of FIG. 68.

DETAILED DESCRIPTION OF THE PREFERRED EMBODIMENT

Referring to FIGS. 1-6, the instrumentation of the present invention comprises a milling block, generally referred to by the numeral 100. The milling block 100 has an overall generally rectangular configuration having a front face 102, an opposite rear face 104, a top side 106, a bottom side 108 and left and right sides 110 and 112, respectively. The front face 102 comprises a surface having a concave configuration that conforms to the natural curvature of the anterior aspect of a segment of the human spinal column and permits the placement of the milling block 100 in close proximity to the anterior aspect of the spinal column. The milling block 100 comprises a central aperture 114 through the center of the milling block 100. The aperture 114 is preferably oblong-shaped, having an approximate width of 18-30 mm for use in the cervical spine, 30-50 mm for use in the lumbar spine, and if the milling block 100 is used on the left and right sides of the mid sagittal axis of a lumbar vertebrae separately, the approximate width of the aperture 114 is 15-25 mm and the approximate height of the aperture 114 is 5-20 mm. Located within the aperture 114 is a sliding mill guide 116 having a threaded port 118 for engaging various instrumentation as discussed in detail below. The mill guide 116 slides in a

11

transverse motion from side to side within the central aperture **114** along the transverse axis of the aperture **114**.

The milling block **100** comprises a plurality of pin holes **120a-d** which pass through the milling block **100** from the rear face **104** through the front face **102**. The pin holes **120a-d** have a wider diameter entrance at the rear face **104** of the milling block **100** and have a narrower diameter passage at the front face **102** of the milling block **100**. The wide diameter entrance of the pin holes **120a-d** permit the countersinking of the head portion **126** of pin **128** illustrated in FIGS. 7A and 7B and described in detail below.

The rear face **104** of the milling block **100** includes blind holes **130** and **132** centrally positioned and located between the pin holes **120a-b** and **120c-d**, respectively. The blind holes **130** and **132** receive posts **134a** and **134b** of the distractor holder **158** illustrated in FIG. 9 and described in detail below. The top and bottom sides **106** and **108** of the milling block **100** comprise tracks **136a** and **136b** having an inverted T-shaped configuration for engaging a T-shaped rail member **138** of the handles **140** and **142** illustrated in FIG. 8 and described in detail below. Each of the tracks **136a** and **136b** have a depression **144** for engaging a detent means **146** on the handles **140** and **142** for centering the handles **140** and **142** relative to the milling block **100** and for locking the handles **140** and **142** in place once they are attached to the milling block **100**.

Referring to FIG. 8, the handle **140** is shown having a general L-shaped configuration with an inverted T-shaped rail member **138** for engaging the tracks **136a** and **136b** of the milling block **100**. The handle **140** has detent means **146** located in the center of the rail member **138** which fits into the depression **144** of the tracks **136a** and **136b** and functions to center and lock the handle **140** to the milling block **100**.

Referring to FIG. 9, the distractor apparatus of the present invention generally referred to by the numeral **150** is shown in an exploded view in relation to milling block **100**. The distractor apparatus **150** comprises a distractor **151** having a cylindrical shaft **152** with a bullet-shaped leading end **154**. The distractor **151** is interposed in the disc space between two adjacent vertebrae and bears upon the endplates of the adjacent vertebrae to urge the vertebrae apart. The leading end **154** of the distractor **151** is a flattened member having a height that may correspond to the normal anatomic height of the disc space between two adjacent vertebrae in which the distractor **151** is to be inserted or may have a height that is less than the anatomic height of the disc space. It is appreciated that the distracted height of the disc space may be equal to, less or greater than the normal anatomic height of the disc space. The shaft **152** of the distractor **151** has a plurality of annular slots **156** for engaging the distractor holder **158**.

The leading end **154** of the distractor **151** may have a height in the range of 4 mm to 20 mm, with 10 mm to 14 mm being the preferred height in the lumbar spine except for a collapsed and degenerated disc which may be less, 5.5 mm to 7.5 mm being the preferred height in the cervical spine. The distractor **151** may have a thickness in the range from 1 mm to as great as 20 mm in the cervical spine, with 2 mm being the preferred thickness. In the lumbar spine the distractor **151** may be from 2 mm to 50 mm thick with a range of 2 mm to 5 mm being preferred. The length of the portion of the leading end **154** of the distractor **151** extending beyond the front face **102** of the milling block **100** (referred to herein as the "penetration depth") is less than the depth of the disc space at that location. The "depth" of the disc space is the distance between the anterior and posterior aspect of a vertebrae; the "width" of the disc space is the distance between the lateral aspects of a vertebrae; and the "height" of the disc space is the distance

12

between two vertebral endplates adjacent to the disc space. For the cervical spine, the length of distractor **151** would range from 8 mm to 20 mm, with 10-15 mm being preferred as measured at the sagittal (left from right) midline; while in the lumbar spine the distractor **151** length would range from 15 mm to 40 mm, with 20 mm to 35 mm being preferred.

Referring to FIGS. 9-10 the distractor holder **158** has an inverted Y-configuration with a central tubular member **160** and a base member **160**. The bottom portion **164** of the tubular member **160** has side slots **166** having a width sufficient to accommodate the thickness of the leading end **154** of the distractor **151**. Located over the bottom portion of the tubular member **160** is a sleeve **168** which engages the bottom portion **164** and rotates freely about the bottom portion **164** of the tubular member **160**. The sleeve **168** has an external thread **170** for engaging the milling port **118** of the sliding mill guide **116** and knob **171** for rotating the sleeve **168**. The sleeve **168** engages the opening **186** in the drill insertion end **184** of the calibration gauge **180** illustrated in FIG. 11A and described in detail below.

Depending from the base member **162** of the distractor holder **158** are posts **134a** and **134b** for centering and engaging the distractor holder **158** to the milling block **100** and to the distractor insertion end **182** of the calibration gauge **180**. The posts **134a** and **134b** fit into the blind holes **130** and **132** of the milling block **100** and also fit into the blind holes **188a** and **188b** of the calibration gauge **180**.

The upper portion **172** of the tubular member **160** of the distractor holder **158** has a spring loaded locking collar **174** for locking the distractor **151** to the distractor holder **158** after the distractor **151** is inserted into the distractor holder **158**. The distractor holder **158** holds the distractor **151** with a spring loaded gripping member **176** that is configured to engage the annular slots **156** in the shaft **152** of the distractor **151**. The locking collar **174** is locked and unlocked by the partial rotation of the locking collar **174** about the upper portion **170** of the tubular member **160**. The locking collar **174** is kept in a "locked" or "unlocked" position by slot **173** and pin **175**.

In the locked position, the locking collar **174** forces the gripping member **176** into the annular slots **156** of the shaft **152** of the distractor **151** to hold the distractor **151** within the distractor holder **158**. The gripping member **176** has tynes **177** with an enlarged head portion **178** which has a complementary configuration for fitting the annular slots **156** of the distractor **151**. The gripping member **176** is locked by sliding the locking collar **174** in a direction away from the base **162** such that the locking collar **174** slides over the gripping member **176** to compress the tynes **177** into the slots **156**. To unlock the distractor holder **158**, the locking collar **174** is rotated and slid in the direction toward the base **162** to release the tynes **177** as shown in FIG. 9.

Referring to FIG. 11A, a calibration gauge **180** is shown for setting the depth of the distractor **151** within the distractor holder **158** and for setting the depth of the milling instrument **200** in the coupling member **208** described in detail below. The calibration gauge **180** has a substantially rectangular configuration with a distractor insertion end **182** and a drill insertion end **184**. The distractor insertion end **182** has an opening **186** of a sufficient diameter for receiving the leading end **154** of the distractor **151** and a portion of the sleeve **168** of the distractor holder **158**. The distractor insertion end **182**, has two blind holes **188a** and **188b** for receiving the posts **134a** and **134b** of the distractor holder **158**. Similarly, the drill insertion end **184** has an aperture **190** of a sufficient diameter for receiving and setting the depth of a milling instrument **200**.

13

Referring to FIGS. 11B and 11D, a side elevational view of a distractor **151** having parallel top and bottom sides **153a** and **153b** is shown inserted in the disc space between adjacent vertebrae V.sub.1 and V.sub.2. The distractor **151** is used to place and keep the two adjacent vertebrae V.sub.1 and V.sub.2 in parallel spatial relationship when the distractor **151** is inserted in the disc space with the top and bottom sides **153a** and **153b** placed against the vertebral endplates of the adjacent vertebrae V.sub.1 and V.sub.2. As shown in FIG. 11D, the distractor **151** is placed between two adjacent vertebral V.sub.1 and V.sub.2 to orient and maintain the vertebrae in parallel relationship to each other.

Referring to FIGS. 11C and 11D, a side elevational view of distractor **151'** is shown having top and bottom sides **153a'** and **153b'** in a converging angular relationship to each other. The distractor **151'** is used to place and keep two adjacent vertebrae V.sub.2 and V.sub.3 in angular relationship to each other, such as where the restoration of lordosis is desired at a specific disc level of the spine. As shown in FIG. 11D, the distractor **151'** is placed between two adjacent vertebrae V.sub.2 and V.sub.3 to orient and maintain the vertebrae in angular relationship to each other.

Referring to FIG. 12, the calibration gauge **180** for calibrating the depth of the distractor **151** within the distractor holder **158** is shown. The calibrator gauge **180** is hollow and has a window **192** with graduated marks **194** indicating the depth in which the distractor **151** being held by the distractor holder **158** will penetrate the disc space between two adjacent vertebrae when the distractor **151** is subsequently inserted into the disc space as described in detail below.

In one embodiment of the calibration gauge **180**, for use in the cervical spine, the graduated marks **194** range from 11 to 21 mm to represent the length of insertion of the distractor **151** which penetrates the disc space. The distractor **151** is selected and inserted into the distractor holder **158** and remains in the unlocked position as shown in FIG. 12. The leading end **154** of the distractor **151** is then placed within the aperture **186** of the calibration gauge **180** such that the leading end **154** of the distractor **151** becomes visible through the window **192**. The desired depth of the distractor **151** may be selected in reference to the graduated marks **194** by adjusting the distractor **151** in relation to the distractor holder **158** such that the desired amount of the distractor **151** extends within the calibration gauge **180**. The depth adjustment of the distractor **151** is accomplished by sliding the shaft **151** of the distractor **151** up or down in relation to the distractor holder **158**. Once the correct depth suitable for the disc space in which the distractor **151** is to be inserted has been selected for the distractor **151**, the locking collar **174** on the distractor holder **158** is rotated and moved to compress the tynes **177** of the gripping member **176** into the annular slots **156** of the distractor **151** and the distractor **151** is held in fixed relationship to the distractor holder **158** at the desired depth. In the preferred embodiment, the annular slots **156** are spaced apart a distance corresponding to each of the graduated marks **194** to facilitate the depth selection and adjustment of the distractor **151** within the distractor holder **158**. The distractor holder **158** is then dissociated from the calibration gauge **180** and the distractor **151** remains in fixed position in the distractor holder **158** since the distractor holder **158** is in the "locked" position. In the alternative, as shown in FIGS. 9 and 11A-11C, each of the annular rings **156** is numbered for length which can be read directly from the shaft **152** as the number appearing beyond the gripping member **176**.

Referring to FIGS. 13 and 14, the distractor holder **158** with the distractor **151** locked in place is coupled to the milling block **100** such that the leading end **154** of the dis-

14

tractor **151** passes through the threaded port **118** of the mill guide **116**. The posts **134a** and **134b** of the distractor holder **158** are positioned within the blind holes **130** and **132** of the milling block **100** and the sleeve **168** of the distractor holder **158** is threadably coupled to the threaded collar port **118** of the milling block **100**. The handles **140** and **142** are engaged to the milling block **100** with the rail member **138** in the tracks **136a** and **136b** and the detent means **146** positioned within the depression **144** of the tracks **136a** and **136b**.

The combined distractor apparatus **150** and milling block **100** assembly is then brought to the fusion site of the spine S from the anterior aspect of the spine S and the leading end **154** of the distractor **151** is then introduced into the disc space D between two adjacent vertebrae V.sub.1 and V.sub.2. It is appreciated that the distractor **151** may be introduced into the disc space D turned on its side (with the sides **153a** and **153b** parallel to the horizontal plane of the disc space D) so as to facilitate introduction of the distractor **151** into the disc space D and then turned 90 degrees position the sides **153a** and **153b** of the distractor **151** perpendicular to the horizontal plane of the disc space D to distract the vertebrae V.sub.1 and V.sub.2. Alternatively, the distractor **151** may be introduced with the sides **153a** and **153b** perpendicular to the horizontal plane of the disc space D, relying on the bullet-shaped leading edge **154** to distract the vertebrae V.sub.1 and V.sub.2 apart during insertion. The angular relationship of the two vertebrae V.sub.1 and V.sub.2 adjacent to the disc space D will then be determined by the shape of the distractor **151** as illustrated in FIG. 11D and previously described above.

Referring to FIGS. 14 and 15, the front face **102** of the milling block **100** is placed adjacent to the segment of the spine S in which the fusion or artificial disc implantation is being performed. The milling block **100** is then secured to the anterior aspect of the spine S by engaging each of the adjacent vertebrae V.sub.1 and V.sub.2 by inserting pins **128a-d** with a pin driver **196**. The pins **128a-d** are inserted into the pin holes **120a-d** and pass through the milling block **100** and penetrate the bone of the vertebrae V.sub.1 and V.sub.2 to engage the milling block **100** to the spine S. It is appreciated that while two pins **128** into each of the adjacent vertebrae are shown, other engaging means such as a screw, or more or less of such engaging means to engage the milling block **100** to the spine, could also be used, such as prongs fixedly attached and extending forward from the milling block **100**. After the milling block **100** is secured to the vertebrae V.sub.1 and V.sub.2 of the spinal column, the distractor holder **158** and the distractor **151** are removed from the disc space D and the handles **140** and **142** are removed from the milling block **100** as shown in FIG. 15. It is now possible for the surgeon to view the vertebrae V.sub.1 and V.sub.2 through the central aperture **114** of the milling block **100** so that the width and depth of the desired bone resection from each of the adjacent vertebrae may then be easily confirmed visually prior to performing any actual bone resection.

Referring to FIGS. 16-18B, the milling apparatus of the present invention, generally referred to by the numeral **200** is shown. The milling apparatus **200** is a bone removal device used to mill (remove a portion of bone from) the endplates of the vertebrae V.sub.1 and V.sub.2 adjacent to the disc space D in which a spinal implant is to be inserted. The milling apparatus **200** comprises a milling bit **202** having a shaft **204** terminating in a cutting portion **206** having a cutting end and a cutting perimeter for cutting bone. The shaft **204** is configured to fit within a driver coupling member **208** for coupling the milling bit **202** to a driving device, well known in the art, such as motorized drill or gas driven turbine (not shown). The driver coupling member **208** has a shaft receiving end **210** for

15

receiving the shaft **204** of the milling bit **202**, an annular segmented collar portion **212**, and a driver coupling end **214** for coupling to a driving device. While gas driven turbines are known and are presently manufactured and sold by Midas Rex, Anspach, Zimmer, Inc. and others, all these units attach to a gas driven turbine and hold a burr, but lack any adjustable depth limiting means, such as the adjustable depth limiting means of the present invention so as to be able to be lockably engaged into a further apparatus such as is required in the present invention.

A locking adapter **216** functions to lock the milling bit **202** to the driver coupling member **208**, to couple the milling bit **202** to the calibration gauge **180**, and to couple the milling bit **202** to the port **118** of the mill guide **116** of the milling block **100**. The locking adapter **216** comprises a hollow tubular sleeve **218** and has a similar configuration to the locking collar **174** of the distractor holder **158** described above. The sleeve **218** has a locking collar **220** and a spring-loaded gripping member **222** similar to the locking collar **174** and gripping member **176** described above. The locking adapter **216** has a bottom portion **224** of the sleeve **218** for coupling to the drill insertion end **184** of the calibration gauge **180**. An adaptor fitting **226** is provided having a threaded portion **228** for engaging the threaded port **118** of the milling guide **116**.

The proper diameter milling bit **202**, corresponding to the space to be created between the adjacent vertebrae is adjusted with the calibration gauge **180** to select the appropriate maximum safe penetration depth into the disc space of the milling bit **202** to prevent unwanted over penetration into the disc space. After the milling bit **202** is inserted into the calibration gauge **180**, the length of the milling bit **202** that is capable of extending through the milling block **100** is adjusted in reference to the calibration marks **194** of the calibration gauge **180** and the milling bit **202** is then locked to the driver coupling member **208**.

For example, if the desired length of the milling bit **202** extending into the milling block **100** is 15 mm (determined by the dimensions of the vertebrae being milled), then the milling apparatus **200** would be coupled to the calibration gauge **180** and the driver coupling member would be advanced toward the calibration gauge **180** until the tip of the cutting portion **206** is aligned with the graduated marks **194** corresponding to 15 mm. The locking adapter **216** is then rotated and placed in the locked position with the gripping member **222** engaging the segment on the collar portion **212** corresponding to 15 mm.

It is appreciated that other means for setting the depth of the milling bit **202** are contemplated to be within the scope of the present invention. For example, with reference to FIG. **18A** the segments of the collar portion **212** of the milling apparatus **200** can include calibration marks corresponding to the depth of the milling bit **202** extending through and protruding from the milling block **100**. In this manner, the gripping member **222** is set to engage the appropriate segment of the collar **212** corresponding to the desired depth. Similarly, the annular slot **154** on the shaft **152** of the distractor **151** may include calibration marks for setting the desired depth of the distractor **151** without the use of a calibration gauge **180**.

It is further appreciated that the milling apparatus may comprise any suitable bone removal means such as, but not limited to, burrs, router bits, abraders, grinders, rasps, drills, graters, saws, oscillating cutters, vibrating cutters, reciprocating cutters, orbital cutters, rotating cutters and lasers.

Referring to FIGS. **18B** and **19**, the milling apparatus **200** is then inserted through the adaptor fitting **226** and is screwed to the port **118** of the milling block **100**. The milling bit **202** is then rotated at high speed as illustrated by arrow R in FIG.

16

19. The milling apparatus **200** rotating at high speed is moved in the direction illustrated by arrow A and the portions of the vertebrae V.sub.1 and V.sub.2 adjacent to the disc space are then milled to create a space for receiving an implant. After the creation of the space for the implant, the milling apparatus **200** is removed from the milling block **100** and the prepared space may be irrigated and suctioned through the port **118** of milling block **100**, or alternatively the entire milling assembly including the milling block **100** may first be removed and the space then irrigated and suctioned. The disc space D is distracted utilizing conventional means and the appropriate implant or implants are then inserted into the newly prepared space.

Referring to FIGS. **20-22**, a segment of the spinal column S is shown with an implant I inserted between the two adjacent vertebrae V.sub.1 and V.sub.2 in the space created with the milling instrumentation and method of the present invention. As shown in FIG. **22**, the space B created by the milling block **100** is substantially rectangular in shape and extends across the width and length of the vertebrae V.sub.1 and V.sub.2 to create a large area of contact between the vertebrae V.sub.1 and V.sub.2 and the implant I, which may have a curved (from side to side) trailing end to conform to the curvature of the vertebrae.

Referring to FIG. **23**, although implant I has been shown to have the substantially rectangular configuration it is appreciated that the implant I' can have a modified configuration with curved side walls (e.g. left and right) as shown in FIG. **23**.

Referring to FIGS. **24-26**, the space C created with the instrumentation and method of the prior art is shown with an implant I' inserted therein. In comparing the size of the space C with the size of the space B shown in FIG. **22** created by the method and instrumentation of the present invention, it is clear that the space B created with the instrumentation of the method of the present invention is substantially greater than was possible with the instrumentation and methods of the past. As a result, the spinal implant I inserted in the space B can be substantially larger than implant I' and have a substantially greater surface area of contact with the vertebrae V.sub.1 and V.sub.2 providing greater stabilization to the segment of the spine S being fused.

Furthermore, it can be seen in FIG. **22** that with the present invention the implant can not only engage the very strong bone of the vertebral body at the endplate located posteriorly (in the back) and laterally (to each side), but as shown in FIG. **20**, the implant may be embedded into sockets in the posterolateral corners of the vertebrae (dark shaded areas shown in FIGS. **20-26**) providing enhanced stability to the implant which is blocked from moving more posteriorly or to either side.

Referring to FIGS. **27-35**, an alternative embodiment of the milling block of the present invention is shown and generally referred to by the numeral **300**. The milling block **300** has a similar configuration to the milling block **100** described above, and comprises a modified distractor element **351** for separating and orienting the adjacent vertebrae in the appropriate relationship to each other prior to milling the space in which an implant is to be inserted. The distractor element **351** is inserted in an inverted T-shaped slot **301** in the front face **302** of the milling block. **300**. The slot **301** comprises a spring loaded detent means **303** which functions to hold the distractor member **351** in place once it is inserted within the slot **301**.

Referring to FIG. **33** a perspective view of the distractor element **351** is shown having an inverted T-shaped rail member **353** which corresponds in configuration to the inverted T-shaped slot **301**. The distractor element **351** has an insertion

end **355** that is tapered and bullet shaped to facilitate insertion into the disc space D between two adjacent vertebrae V.sub.1 and V.sub.2. The distractor element **351** is inserted into the slot **301** of the milling block **300** prior to attaching the milling block **300** to the segment of the spine S in which the fusion is desired. The distractor element **351** has a biconcave configuration to conform to the curvature of the cutting end **206** of the milling bit **202** of the milling apparatus **200**, as described above, such that the horizontal excursion of milling bit **202** on either side of the distractor element **351** is maximized when used to create a space in the adjacent vertebrae V.sub.1 and V.sub.2. It is appreciated that the distractor element **351** may come in different lengths in order to accommodate for the different dimensions of the disc space between the two adjacent vertebrae in which the surgical procedure is to be performed.

Referring to FIGS. **30** and **35**, the track members **336a** and **336b** are located on the sides of the milling block **300** such that handles **340** and **342** may be attached to the milling block **300** as previously described herein. The track members **336a** and **336b** each have a detent means **343a** and **343b**, respectively, for holding the handles **340** and **342** as shown in FIG. **30**.

Referring to FIGS. **36-37**, an alternative embodiment of the milling apparatus generally referred to by the number **361** is shown. The milling apparatus **361** comprises a coupling member **308** which is identical to coupling member **208** previously described. The milling apparatus **361** includes a milling bit **365** with a cutting portion **367** and a shaft portion **369** that are similar to the milling bit **202** previously described. Milling bits such as **365** are known and commercially available. The element of milling bit **365** as well as the use of an element such as milling bit **365** with a coupling means such as coupling member **308** are well known in the art. An adaptor sleeve **371** is used to couple the coupling member **308** and the milling bit **365** to the port **318** of the milling block **300**. The sleeve **371** comes in a variety of lengths depending on the desired depth of the space to be created and functions to limit the excursion of the milling bit **365** into the milling block **300**. The longer the sleeve **371**, the less the excursion of the milling bit **365** into the disc space between two adjacent vertebrae in which the opening is desired to be created. Thus, the surgeon can predetermine the depth of the space being created by selecting the appropriate sleeve **371** length prior to performing the procedure.

Referring to FIGS. **38-42** an alternative embodiment of the milling block of the present invention is shown and generally referred to by the numeral **400**. The milling block **400** comprises a central template **401** for creating a space of any desired shape and as an example, the space to be created may be a substantially rectangular space corresponding to the shape of the rectangular template **401**. The template **401** has a track **407** passing through the milling block **400** from the rear face **404** to the front face **402** of the milling block **400**. The track **407** is configured to receive a suitable bone removal means such as a drill a router or a laser, and the like, to remove a portion of the bone of the adjacent vertebrae milling instrument **403** and serves as a guide for creating the desired space in the adjacent vertebrae with a suitable bone removal means including, but not limited to, a router, to remove a portion of the bone of the adjacent vertebrae. The milling instrument **403** is inserted into a collar **405** which fits into the track **407** and is retained in slidable relationship within the track **407** of the template **401** and functions to guide the travel of the milling instrument **403** within the track **407**. The drilling instrument **403** is then activated and moved within the confines of the track **407** to create the desired space in the verte-

brae, which space can be of a shape corresponding to the shape of track **107** of the template **401**. This is particularly useful for creating a shape, such as that shown in FIG. **45**, which might be desirable for installing an artificial disc device **409** between two adjacent vertebrae.

Referring to FIGS. **43** and **44**, alternative embodiments of the milling block **400** designated as **400'** and **400''** are shown engaging two adjacent vertebrae V.sub.1 and V.sub.2 shown in hidden line. Tracks **401'** and **407''** are configured to create a space such as shown in FIG. **44** for receiving an artificial implant or an artificial joint as shown in FIG. **45**. It is appreciated that in addition to the foregoing configurations of the template **400**, that other configurations are possible and contemplated to be part of the present invention.

Referring to FIGS. **46** and **47** an alternative embodiment of the milling block of the present invention is shown and generally referred to by the numeral **500**. The milling block **500** is similar in configuration to the milling block **300** previously described above and comprises a pair of removable distractor elements **551a** and **551b** which are inserted in complimentary inverted T-shaped slots **553a** and **553b** at opposite sides of the milling block **500**. The distractor elements **551a** and **551b** are inserted in the disc space D and function to restore the height of the disc space D prior to the milling operation to create the desired space. The distractor elements **551a** and **551b** are oriented at the sides of the central aperture **514** and each have a concave surface facing the central aperture **514** to conform to the curvature of the milling instrument such as milling bit **206**, used to create the space between the two adjacent vertebrae. The lateral placement of the distractor elements **551a** and **551b** allows for the full side-to-side motion of the milling guide **516** to permit the unimpeded milling and creation of the space and without the need for having to remove and reinsert the milling instrument in order to get around a centrally placed distractor element such as distractor element **351** shown in FIG. **32**.

Referring to FIGS. **48-49**, an alternative embodiment of the milling block assembly of the present invention is shown and generally referred to by the numeral **600**. The milling block **600** is substantially the same as the milling block **500** described above except that the pair of distractor elements **651a** and **651b** are joined at their distal ends by a cross bar **655**. Cross bar **655** serves as a depth limiting means to any debris and to keep the pair of distractor elements **651a** and **651b** together as a unit.

Referring specifically to FIG. **50**, an alternative embodiment of the milling block **600'** is shown and generally referred to by the numeral **600'**. The milling block **600'** instead of utilizing pins **128a-128d** to engage the vertebrae, a centrally placed prongs **603a** and **603b** to engage the milling block **600'** to the adjacent vertebrae. The prongs **603a** and **603b** are an integral part of the milling block **600'** or may also be removable, like pins **128a-d** discussed above, as an example. It is further appreciated that the milling block **600** may engage the adjacent vertebrae via the distractor elements **651a** and **651b** positioned within the disc space to secure the milling block **600** to the spine. The tension forces generated by the distraction of the disc space from the insertion of the distractor elements **651a** and **651b** engage the vertebrae to the distractor elements **651a** and **651b** and functions to hold the milling block **600** to the spine.

Referring to FIGS. **51-57**, the preferred embodiment of the milling block for use in the cervical spine of the present invention generally referred to by the number **700** is shown. The milling block **700** is shown with a distractor holder **758** which is capable of being coupled directly to the milling block **700**. The distractor holder **758** has a pair of rotating post

members **734a** **734b** and foot portions **737a** and **737b**, respectively, and handle portions **774a** and **774b**, respectively. The rear surface **704** of the milling block **700** comprises pin grooves **721a-721d** for receiving pins, such as pins **128**, previously described. The rear surface **704** also includes post grooves **723a** and **723b** for receiving the post members **734a** and **734b** in which the foot portions **737a** and **737b** of the post members **734a** and **734b** engage the lips of the post grooves **723a** and **723b** to lock the distractor holder **758** to the milling block **700**.

The distractor holder **758** comprises of a gripping portion **776**, similar to gripping member **176** previously described, for engaging a distractor, such as distractor **150** previously described. The distractor holder **758** is capable of locking the distractor **150** in the desired position in order to limit the excursion of the distractor end **154** into the disc space.

Referring specifically to FIG. **57**, a fragmentary perspective view of the post member **734a** is shown having a spring loaded detent means **790**. The detent means **790** is seated in a recess **791** and is biased by spring **792**, functions to lock the rotating post member **734a** in place once engaged to the milling block **700**. Prior to engaging the distractor holder **758** to the milling block **700**, the desired length of the distractor **150** is set by engaging the calibration gauge **780** having one end capable of receiving the distractor holder **758**. The depth of the distractor **150** is set according to the graduated marks **794** on the calibration gauge **780**, or in the alternative as previously described by reference to the depth markings on the annular rings of the distractor. Once the desired length is selected, the distractor holder **758** is locked onto the distractor **150** in the same manner described above. The distractor holder **758** is then coupled to the milling block **700** with the sleeve **764** engaging the port **718** of the milling block **700**. The post members **734a** and **734b** are then locked into place by rotating the handle portions **774a** and **774b** so that the foot portions **737a** and **737b** are engaging the post grooves **723a** and **723b** of the rear surface **704** of the milling block **700**. Once the distractor holder **758** is engaged to the milling block **700**, the pins, such as pins **128a-d**, are inserted into the pin holes **721a-721d** and the milling block **700** is engaged to the adjacent vertebrae.

After the milling block **700** is engaged to the adjacent vertebrae, the distractor holder **758** is removed and the adjacent vertebrae are held in the correct spatial relationship by the milling block **700** and pins **128a-d**. It is appreciated that to facilitate the engagement and removal of the distractor holder **758**, the calibration gauge **780** has a receiving end **781** for engaging the shaft to the distractor **151** such that the distractor holder **758** and distractor can be manipulated with the calibration gauge **780** serving as a handle. In this embodiment the distractor **151** has a flattened end portion **152** with a detent **155** as shown in FIG. **11A**, to couple the distractor **151** to the calibration gauge **780**.

The preparation and creation of the space between the adjacent vertebrae with milling block **700** is performed in the similar manner described above with a milling apparatus such as milling apparatus **200** described above and shown in FIG. **16**.

Referring to FIGS. **59-61**, an alternative embodiment of the milling block of the present invention is shown and generally referred to by the numeral **800**. The milling block **800** comprises of a template **801** having a narrow track **807** for receiving a bone removal device such as an oscillating blade **809** as shown in FIG. **61**. The narrow track **807** functions to support and guide the motion of the oscillating blade **809** in the selected path of the track **807**. Therefore, the track **807** can function as both means for accessing the adjacent vertebrae

V.sub.1 and V.sub.2 and as a guiding means for guiding a bone removal instrument. The oscillating blade **809** is used to cut the desired space in the adjacent vertebrae along the track **807** of the template **801**. As shown in FIG. **59** the template **800** is engaged to two adjacent vertebrae shown in hidden line. The milling block **801** maintains the vertebrae V.sub.1 and V.sub.2 in the correct spatial relationship and the cutting of the bone is performed with the oscillating blade **809** to create the desired space. While slotted cutting fixtures are known in the field of orthopedic surgery, their purpose is to resect the end of a long bone, and not a spinal vertebrae; and all examples known to this author work on but a single bone, do not attach to both of the bones that would form a joint and do not fix those bones in a desired spatial and angular relationship so as to create the optimal joint space and conformation.

Referring to FIG. **61** the saw housing **812** lockably engages the saw blade **809** by screw **811** within slot **810**, which coupling means allows the protruding portion of blade **809** to be adjusted for length.

Referring to FIGS. **62** and **63**, an alternative embodiment of the milling block apparatus of the present invention is shown and generally referred to by the numeral **900**. The milling block apparatus **900** is suitable for use in procedures in which the surgeon's hand is at a point remote from the site of the spinal fusion, such as for use in endoscopic procedures, or for performing procedures on the posterior aspect of the spine on either side of the mid-sagittal axis of the vertebrae avoiding the spinal cord and other delicate structures present at the posterior aspect of the spine. The milling block apparatus **900** comprises an elongated member such as a hollow tube **901** having a front end **902** and a rear end **904** with milling guides **916a** and **916b** at each of its ends **902** and **904** for guiding a milling apparatus for creating and preparing the space between the two adjacent vertebrae. Such a milling apparatus would be similar to the milling bit **202** described above, and would have a shaft of sufficient length to span the distance between the milling guides **916a** and **916b** and have a cutting portion capable of passing through the ports **918a** and **918b** and extending into the disc space from the front end **902** of the milling block apparatus **900** for milling the bone of the adjacent vertebrae. In this manner, the desired space for receiving an implant may be created from a position remote from the spine such as would be useful for endoscopic spinal surgery.

The milling block apparatus **900** may be placed directly against the site of the spine in which the procedure is to be performed, with the front end **902** placed across the disc space and contacting the vertebrae adjacent to that disc space. The milling procedure for removing a portion of bone from the adjacent vertebrae to create a space for receiving an implant is performed with a bone removal means as discussed above for the other embodiments of the present invention.

Referring to FIG. **64**, the milling block apparatus **900** may be placed through a combination outer sleeve distractor **980** having a hollow sleeve portion **982** and having extensions members **984** and **986** extending from one end of the sleeve portion **982** for insertion into the disc space. The extension member **984** and **986** function to distract the disc space to its normal height and to engage the combination outer sleeve distractor **980** to the spine. The combination outer sleeve distractor **980** is capable of receiving and guiding the milling block apparatus **900** to the appropriate site in which the milling procedure is to be performed. The elongated tubular body **901** of milling block apparatus **900** would in use pass through the combined outer sleeve distractor **980**, which itself would engage the spine at or adjacent to the disc space to be milled and would itself extend from the spine to outside of the

patient's body. Such a combined outer sleeve distractor is taught by Michelson in co-pending application Ser. No. 08/396,414 filed on Feb. 27, 1995, incorporated herein by reference.

The bone removal from the adjacent vertebrae for creating the space for receiving an implant is performed with the milling block apparatus **900** positioned within the combination outer sleeve distractor **980** with a bone removal device passing through the ports **918a** and **918b** of the sliding mill guides **916a** and **916b**.

The milling block **900** as here taught need not be cylindrical and can be any shape, for example, square or rectangular to conform to the shape of the combination outer sleeve distractor **980**. Furthermore, any such extended milling block **900** may have a flange proximally (rear end) or threads, or other means to fix, its position relative to said outer sleeve.

Referring to FIG. **65**, a side view of a segment of the human spine with two adjacent vertebrae having a milling apparatus **1000** having a shaft **1002** and a cutting portion **1004** for preparing a space for receiving an implant, in which both the anterior and posterior aspects of the adjacent vertebral end-plates have bone retaining walls **1000a** and **1000b**, respectively. The anterior and posterior retaining walls are created by the cutting portion **1004** having a larger diameter than the shaft **1002** of the milling apparatus **1000** and a length which fits within the depth of the adjacent vertebrae. Such a configuration permits the placement of substantially rectangular implant within the prepared space. The retaining walls **1000a** and **1000b** in the anterior and posterior aspects of the end-plates function to lock and secure an implant or bone graft once installed between the two adjacent vertebrae.

While one particular type of bone milling instrument capable of cutting both on its leading end and along its sides has been shown a variety of bone cutting or abrading instruments including a drill rasp, burr, abraider or even a saw blade edge of the oscillating type or other could be used. Further, while the preferred embodiment bone milling means is shown as having a length extending at least as long as the depth of bone to be removed, the bone removal means can have a variety of shapes and lengths.

Referring to FIGS. **66** and **67**, an alternative embodiment of the milling block, generally referred to by the numeral **1100** is shown. The milling block **1100** comprises two separable members: an instrument guiding member **1110** and a distractor base member **1112**. The distractor base member **1112** has a generally rectangular upper portion **1113** having a front face **1102** and a rear face **1104**. The front face **1102** has a concave configuration that conforms to the natural curvature of a segment of the human spinal column and permits the placement of the front face **1102** of the milling block **1100** in close proximity to the spinal column. The upper portion **1113** of the distractor base member **1112** has a recess **1115** for receiving and holding a portion **1119** of the instrument guiding member **1110** of the milling block **1100** and a central opening **1117** through the center of upper portion **1113**. The opening **1117** is preferably oblong-shaped, having an approximate width of 18-30 mm for use in the cervical spine, 30-50 mm for use in the lumbar spine, and if the milling block **1100** is used on the left and right sides of the mid-sagittal axis of a lumbar vertebrae separately, the approximate width of the opening **1114** is 15-25 mm and the approximate height of the opening **1114** is 5-20 mm.

Extending from the upper portion **1113** and extending beyond the front face **1102** are a pair of distractor elements **1151a** and **1151b** similar in configuration to the distractor elements **651a** and **651b** previously described above. The distractor elements **1151a** and **1151b** are capable of being

introduced into the disc space between two adjacent vertebrae to place the vertebrae in a selected spatial relationship. The insertion of the distractor elements **1151a** and **1151b** into the disc space also functions to engage the distractor base member **1112** to the adjacent vertebrae.

The instrument guiding member **1110** of the milling block **1100** has a leading surface **1162**, a trailing surface **1160**, and a central aperture **1114** through its center having a suitable configuration corresponding to the central opening **1117** of the distractor base member **1112**. Located within the aperture **1114** is a sliding mill guide **1116** having a threaded port **1118** for engaging various instrumentation as previously discussed in detail above. The mill guide **1116** slides in a transverse motion from side to side within the central aperture **1114** along the transverse axis of the aperture **1114**.

The leading surface **1162** of the instrument guiding member **1110** is capable of interfacing with the rear face **1104** of the distractor base member **1112** and at least portion **1119** of the instrument guiding member **1110** is capable of being seated within the recess **1115** of the distractor base member **1112**. After the distractor base member **1112** is engaged to the spine with the distractor elements **1151a** and **1152b** inserted into the disc space between two adjacent vertebrae and the instrument guiding member **1110** is seated into the distractor base member **1112**, the removal of bone from the adjacent vertebrae is performed in the same manner as the milling procedure described above.

The milling block **1100** provides the added advantages of allowing the removal of the instrument guiding member **1110** while the distractor base member **1112** remains engaged to the spine maintaining the disc space distracted with the adjacent vertebrae in the appropriate spatial relationship to each other. With the distractor base member **1112** still engaged to the spine, it is possible to introduce an implant through the central opening **1117** and into the space for receiving the implant that has been created across the disc space and into the adjacent vertebrae. After the implant has been inserted into the disc space, the distractor base member **1112** is removed and the implant remains in the space created with the milling apparatus of the present invention.

Referring to FIGS. **68-72**, an alternative embodiment of the milling block of the present invention is shown and generally referred to by the numeral **1200**. The milling block **1200** has a body member **1201** that is capable of extending across the disc space D and capable of engaging at least one of the vertebrae adjacent to the disc space D. The body member **1201** has a front face **1202**, an opposite rear face **1204** and a curved central portion **1205**. It is appreciated that the central portion **1205** need not be curved. The front face **1202** has a surface that permits the placement of the milling block **1200** against the vertebrae. The milling block **1200** has a central aperture **1214** through the center of the body member **1201** for accessing the disc space D between two adjacent vertebrae. Located within the aperture **1214** is a sliding mill guide **1216** having a groove **1217** for slideably engaging the body member **1201** to permit slideable movement of the mill guide **1216** relative to the body member **1201**. The mill guide **1216** has a central opening **1219** in communication with the central aperture **1214** and a sliding member **1221** within the central opening **1219** having a port **1218** for coupling the sliding member **1221** to an instrument such as a distractor previously described, or a bone removal device, such as milling apparatus **200** previously described. It is appreciated that the mill guide **1216** in addition to guiding a milling apparatus **200**, is also capable of guiding other instruments into the disc space such as a distractor element used to align the vertebrae and to distract the disc space.

23

The sliding member **1221** of the mill guide **1216** is capable of transverse motion from one side to the other side of the central opening **1219** along the transverse axis of the opening **1219** to guide and control a bone removal device, such as milling apparatus **200**, in a selected transverse path relative to the vertebrae adjacent to the disc space D to remove at least a portion of bone from the vertebrae. The mill guide **1216** of the milling block **1200** is also capable of moving up and down in a vertical direction within the central aperture **1214** along the vertical axis of the aperture **1214**, and along the curved central portion **1205** of the body member **1201**. The vertical motion of the mill guide **1216** guides and controls the milling apparatus **200** in a selected path that may be at an angle to the vertebrae in order to remove an angular portion of bone from the vertebrae. The angular orientation of the milling apparatus **1216** relative to the vertebrae is a result of the position of the mill guide **1216** along the curved central portion **1205** of the body member **1201**. In this manner, an opening having an angular configuration may be created, and with an appropriate implant placed within the prepared opening, the normal anatomic lordotic relationship of the vertebrae adjacent to the disc space D may be restored. Or in the alternative, the vertebrae adjacent to the disc space D could be placed in angular relationship prior to the removal of at least a portion of bone from the vertebrae, or a frusto-conical shaped bone removal device could be employed.

The milling block **1200** has a plurality of screw holes **1220a-b** which pass through the milling block **1200** from the rear face **1204** through the front face **1202**. The screw holes **122a-b** receive screws **1228a-b** for engaging the milling block **1200** to the vertebrae adjacent to the disc space D. Similarly, pins, pegs or other suitable means for attaching the milling block **1200** to the vertebrae adjacent to the disc space D could be utilized.

While the present invention has been described in detail with regards to the preferred embodiment, it is appreciated that other variations of the present invention may be devised which do not depart from the inventive concept of the present invention.

I claim:

1. A bone preparation apparatus, comprising:

a support member having a track therein, said track having a length and a width, the width being transverse to the length, opposed side walls along at least a portion of the length of said track, an opening between said side walls and across the width of said track, and a maximum dimension across said opening and between said side walls, at least a portion of said track being non-linear to provide a pathway being at least in part non-linear;

a bone removal device having a longitudinal axis extending between a proximal portion and a distal portion, said distal portion including a cutting element for cutting bone, said cutting element having a maximum cross-sectional dimension transverse to the longitudinal axis of the bone removal device; and

a guide member movably engaged between said support member and said cutting element, said guide member being positionable within said track and in slideable relationship to said track, said guide member having a mid-longitudinal axis and a dimension transverse to said mid-longitudinal axis greater than the maximum dimension across said opening and between said side walls along said non-linear portion of said track, said guide member when positioned within said track contacting both of said opposed side walls along said maximum dimension of said track, said guide member having a passage therethrough having a dimension transverse to

24

the mid-longitudinal axis greater than the maximum cross-sectional dimension of said cutting element to permit said cutting element of said bone removal device to be inserted into said passage and to access the bone to be cut through said passage, said guide member being adapted to movably guide said cutting element within at least said non-linear portion of said track to control movement of said cutting element along at least said non-linear portion of said track to form a selected shape in bone, the shape being at least in part non-linear.

2. The apparatus of claim 1, wherein said bone removal device is coupled to a power source adjacent said proximal portion of said bone removal device.

3. The apparatus of claim 1, wherein a portion of said track forms a curve.

4. The apparatus of claim 3, wherein the selected shape formed by said bone removal device in the bone has a curve corresponding to the curvature of said track.

5. The apparatus of claim 1, wherein said guide member has an outer perimeter surrounding the mid-longitudinal axis, the outer perimeter being at least in part arcuate.

6. The apparatus of claim 5, wherein said outer perimeter is circular.

7. The apparatus of claim 1, wherein said guide member has a height along the mid-longitudinal axis, said guide member having an outer cross sectional dimension that varies along the height of the guide member to control movement of said bone removal device relative to said support member.

8. The apparatus of claim 1, further comprising a second guide member moveably engaged between said support member and said bone removal device.

9. The apparatus of claim 1, wherein said track permits said bone removal device to move in a direction along the longitudinal axis of said bone removal device and in a direction transverse to the longitudinal axis of said bone removal device.

10. The apparatus of claim 1, in combination with an insert adapted to be inserted into the space formed with said apparatus.

11. The apparatus of claim 10, wherein said insert is one of a fusion implant, an interbody spinal implant, an artificial disc, and a bone graft.

12. The apparatus of claim 10, wherein said insert has sidewalls that are at least in part curved.

13. The apparatus of claim 10, wherein said insert has a shape corresponding to the shape of the space created with said apparatus.

14. The apparatus of claim 10, wherein said insert has a trailing end that is curved side to side.

15. The apparatus of claim 10, wherein said insert is in combination with an osteogenic material.

16. The apparatus of claim 15, wherein said osteogenic material includes at least one of bone and hydroxyapatite.

17. A kit, comprising:

an implant having an external perimeter having a defined shape for engagement with a bone surface, said defined shaped of said implant being at least in part non-linear;

a guide body having a pathway with a non-linear portion;

a bone removal device having a mid-longitudinal axis extending between a proximal portion and a distal portion, said bone removal device having a cutting element proximate said distal portion, said cutting element having a maximum dimension in a plane transverse to said mid-longitudinal axis of said bone removal device; and

a guide member positionable within said pathway, said guide member including a passage therethrough having a mid-longitudinal axis, said passage having a maximum

25

dimension transverse to the mid-longitudinal axis of said passage greater than the maximum dimension of said cutting element of said bone removal device, said passage configured to permit said cutting element of said bone removal device to be inserted into said passage and to access the bone to be cut through said passage, said guide member being movably engaged between said guide body and said bone removal device, said guide member being adapted to movably guide said bone removal device within said pathway, said pathway including said non-linear portion having a predetermined pattern substantially corresponding to the defined shape of the implant, said guide member being adapted to move said bone removal device along at least said non-linear portion of said pathway in a direction transverse to the longitudinal axis of said bone removal device to make a non-linear cut into the bone.

18. The kit of claim 17, wherein said implant is an artificial disc.

19. The kit of claim 17, wherein the predetermined pattern is at least in part non-linear in a plane transverse to the longitudinal axis of said bone removal device.

20. The kit of claim 17, wherein said guide member has a mid-longitudinal axis and an outer perimeter surrounding the mid-longitudinal axis, said outer perimeter being at least in part arcuate.

21. The kit of claim 20, wherein said outer perimeter is circular.

22. The kit of claim 17, wherein said implant has sidewalls that are at least in part curved.

23. The kit of claim 17, wherein said implant has a trailing end that is curved side to side.

24. The kit of claim 17, wherein said implant is in combination with an osteogenic material.

25. The kit of claim 24, wherein said osteogenic material includes at least one of bone and hydroxyapatite.

26. The kit of claim 17, wherein said bone removal device may be movably guided by said guide member with respect to said guide body through a fixed predetermined pattern.

27. The kit of claim 17, wherein said bone removal device may be movably guided by said guide member with respect to said guide body through a single predetermined pattern.

28. A bone preparation apparatus for forming a space in bone, said apparatus comprising:

- a bone removal device having a mid-longitudinal axis extending between a proximal portion and a distal portion, said bone removal device having a cutting element proximate said distal portion, said cutting element having a maximum dimension in a plane transverse to said mid-longitudinal axis of said bone removal device;

- a support member having a hollow interior adapted to receive at least a portion of said bone removal device, said support member adapted to hold said bone removal device in a fixed relationship to the bone; and

26

- a guide member movably engaged between said support member and said bone removal device to control movement of said bone removal device in a defined path within said support member to create the space in the bone having a selected shape, said guide member including a passage therethrough, said passage having a mid-longitudinal axis and a maximum dimension transverse to the mid-longitudinal axis of said passage greater than the maximum dimension of said cutting element of said bone removal device to permit said cutting element of said bone removal device to be inserted into said passage and to access the bone to be cut through said passage, said defined path being at least in part curved so as to guide said bone removal device along said defined path to form the space including a curve.

29. The apparatus of claim 28, wherein said path is a track.

30. The apparatus of claim 28, wherein the shape formed by said bone removal device in the bone has a curve corresponding to the curvature of said path.

31. The apparatus of claim 28, wherein said guide member has a mid-longitudinal axis and an outer perimeter surrounding the mid-longitudinal axis, said outer perimeter being at least in part arcuate.

32. The apparatus of claim 31, wherein said outer perimeter is circular.

33. The apparatus of claim 28, wherein said guide member has a mid-longitudinal axis and a height along the mid-longitudinal axis, said guide member having an outer cross sectional dimension that varies along the height of the guide member to control movement of said bone removal device relative to said support member.

34. The apparatus of claim 28, further comprising a second guide member moveably engaged between said support member and said bone removal device.

35. The apparatus of claim 28, in combination with an insert adapted to be inserted into the space formed with said apparatus.

36. The apparatus of claim 35, wherein said insert is one of a fusion implant, an interbody spinal implant, an artificial disc, and a bone graft.

37. The apparatus of claim 35, wherein said insert has sidewalls that are at least in part curved.

38. The apparatus of claim 35, wherein said insert has a shape corresponding to the shape of the space created with said apparatus.

39. The apparatus of claim 35, wherein said insert has a trailing end that is curved side to side.

40. The apparatus of claim 35, wherein said insert is in combination with an osteogenic material.

41. The apparatus of claim 40, wherein said osteogenic material includes at least one of bone and hydroxyapatite.

42. The apparatus of claim 28, wherein said guide member is adapted to move said bone removal device within only two planes.

* * * * *