



US006224595B1

(12) **United States Patent**  
**Michelson**

(10) **Patent No.:** **US 6,224,595 B1**

(45) **Date of Patent:** **\*May 1, 2001**

(54) **METHOD FOR INSERTING A SPINAL IMPLANT**

**FOREIGN PATENT DOCUMENTS**

(75) Inventor: **Gary Karlin Michelson, Venice, CA (US)**

(73) Assignee: **Sofamor Danek Holdings, Inc., Wilmington, DE (US)**

(\*) Notice: Subject to any disclaimer, the term of this patent is extended or adjusted under 35 U.S.C. 154(b) by 0 days.

This patent is subject to a terminal disclaimer.

1961531	7/1970	(DE)
24 46 039	4/1975	(DE)
3101333 A1	12/1981	(DE)
3132520 A1	6/1982	(DE)
3505567 A1	6/1986	(DE)
36 08 163 A1	9/1987	(DE)
0 077 159	4/1983	(EP)
0 162 005	11/1985	(EP)
0 260 044	3/1988	(EP)
0303241 A2	2/1989	(EP)
283078	5/1985	(ES)
2 295 729	7/1976	(FR)
0 179 695	4/1986	(FR)
2 581 336	11/1986	(FR)

(List continued on next page.)

(21) Appl. No.: **09/062,749**

(22) Filed: **Apr. 20, 1998**

(51) **Int. Cl.<sup>7</sup>** ..... **A61B 17/56**

(52) **U.S. Cl.** ..... **606/61; 623/16.1**

(58) **Field of Search** ..... **606/60, 61, 72, 606/73, 74, 86-88; 623/16, 17; 408/222; 470/198**

**OTHER PUBLICATIONS**

Herkowitz, et al.; Principles of Bone Fusion; The Spine, Third Edition; Chapter 44, p. 1739.

Muschler, et al.; The Biology of Spinal Fusion; Spinal Fusion Science and Technique, Cotler and Cotler, pp. 9-13.  
Zindrick, et al.; Lumbar Spine Fusion: Different Types and Indications; The Lumbar Spine, vol. 1, Second Edition, pp. 588-593 (1996).

Gillingham, F.J., et al.; Automatic Patient Monitoring in the Ward; Brit. J. Surg., vol. 53, No. 10, pp. 864-866 (Oct. 1966).

Maloney, A.F.J., et al.; Clinical and Pathological Observations in Fatal Head Injuries, Brit. J. Surg., vol. 56, No. 1, pp. 23-31 (Jan. 1969).

Harris, P., et al.; Spinal Deformity After Spinal Cord Injury; Paraplegia, vol. 6, No. 4, pp. 232-238 (Feb. 1969).

*Primary Examiner*—Michael A. Brown

(74) *Attorney, Agent, or Firm*—Martin & Ferraro, LLP

(56) **References Cited**

**U.S. PATENT DOCUMENTS**

Re. 31,865	4/1985	Roux .
D. 245,259	8/1977	Shen .
D. 257,511	11/1980	Zahn .
D. 260,525	9/1981	Lassiter .
D. 281,814	12/1985	Pratt et al. .
350,420	10/1886	Dillon .
1,137,585	4/1915	Craig .
2,065,659	12/1936	Cullen .
2,181,746	11/1939	Siebrandt .
2,243,718	5/1941	De G. Moreira .
2,372,622	3/1945	Fassio .
2,514,665	7/1950	Myller .
2,537,070	1/1951	Longfellow .
2,543,780	3/1951	Hipps et al. .
2,677,369	5/1954	Knowles .
2,774,350	12/1956	Cleveland .
2,789,558	4/1957	Rush .

(57) **ABSTRACT**

An artificial spinal implant is disclosed which when placed between two adjacent vertebrae directly participates and is incorporated in the ensuing fusion. Instrumentation and procedure is also disclosed.

(List continued on next page.)

**99 Claims, 6 Drawing Sheets**

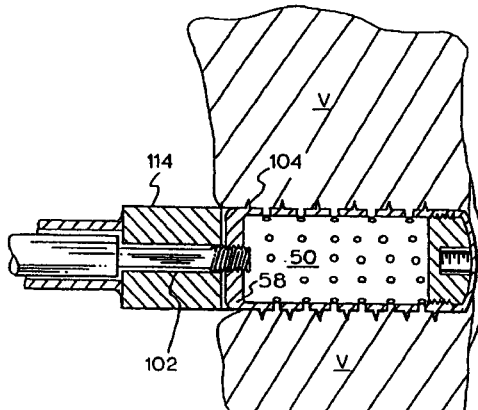

U.S. PATENT DOCUMENTS					
2,832,343	4/1958	Mose .	4,535,374	8/1985	Anderson et al. .
2,842,131	7/1958	Smith .	4,535,485	8/1985	Ashman et al. .
2,878,809	3/1959	Treace .	4,542,539	9/1985	Rowe, Jr. et al. .
3,128,768	4/1964	Geistauts .	4,545,374	10/1985	Jacobson .
3,298,372	1/1967	Feinberg .	4,547,390	10/1985	Ashman et al. .
3,426,364	2/1969	Lumb .	4,549,547	10/1985	Brighton et al. .
3,486,505	12/1969	Morrison .	4,552,200	11/1985	Sinha et al. .
3,604,487	9/1971	Gilbert .	4,553,273	11/1985	Wu .
3,605,123	9/1971	Hahn .	4,554,914	11/1985	Kapp et al. .
3,618,611	11/1971	Urban .	4,570,623	2/1986	Ellison et al. .
3,709,219	1/1973	Halloran .	4,570,624	2/1986	Wu .
3,720,959	3/1973	Hahn .	4,592,346	6/1986	Jurgutis .
3,750,652	8/1973	Sherwin .	4,599,086	7/1986	Doty .
3,848,601	* 11/1974	Ma ..... 623/17	4,600,000	7/1986	Edwards .
3,855,638	12/1974	Pilliar .	4,602,638	7/1986	Adams .
3,867,728	2/1975	Stubstad et al. .	4,604,995	8/1986	Stephens .
3,867,950	2/1975	Fischell .	4,608,052	8/1986	Van Kampen et al. .
3,875,595	* 4/1975	Froning ..... 623/17	4,611,581	9/1986	Steffee .
3,888,260	6/1975	Fischell .	4,619,264	10/1986	Singh .
3,892,232	7/1975	Neufeld .	4,628,921	12/1986	Rouso .
3,905,047	9/1975	Long .	4,634,720	1/1987	Dorman et al. .
3,915,151	10/1975	Kraus .	4,636,217	1/1987	Ogilvie et al. .
3,916,907	11/1975	Peterson .	4,636,526	1/1987	Dorman et al. .
3,918,440	11/1975	Kraus .	4,645,503	2/1987	Lin et al. .
3,942,535	3/1976	Schulman .	4,653,486	3/1987	Coker .
3,948,262	4/1976	Zaffaroni .	4,653,509	3/1987	Oloff et al. .
3,952,334	4/1976	Bokros et al. .	4,655,777	4/1987	Dunn .
3,987,499	10/1976	Scharbach et al. .	4,661,536	4/1987	Dorman et al. .
4,016,651	4/1977	Kawahara et al. .	4,664,567	5/1987	Edwards .
4,027,392	6/1977	Sawyer et al. .	4,665,920	5/1987	Campbell .
4,051,905	10/1977	Kleine .	4,677,883	7/1987	Lee .
4,059,115	11/1977	Jumashev et al. .	4,677,972	7/1987	Tornier .
4,070,514	1/1978	Entherly et al. .	4,693,721	9/1987	Ducheyne .
4,082,097	4/1978	Mann et al. .	4,696,290	9/1987	Steffee .
4,086,701	5/1978	Kawahara et al. .	4,698,375	10/1987	Dorman et al. .
4,124,026	11/1978	Berner et al. .	4,710,075	12/1987	Davison .
4,142,517	3/1979	Stravropoulos et al. .	4,713,004	12/1987	Linkow et al. .
4,168,326	9/1979	Broemer et al. .	4,714,469	12/1987	Kenna .
4,175,555	11/1979	Herbert .	4,721,103	1/1988	Freedland .
4,177,524	12/1979	Grell et al. .	4,736,738	4/1988	Lipovsek et al. .
4,181,457	1/1980	Holmes .	4,743,256	5/1988	Brantigan .
4,197,850	4/1980	Schulman et al. .	4,743,260	5/1988	Burton .
4,206,516	6/1980	Pilliar .	4,759,766	7/1988	Buettner-Janz et al. .
4,222,128	9/1980	Tomonaga et al. .	4,759,769	7/1988	Hedman et al. .
4,232,679	11/1980	Schulman .	4,769,881	9/1988	Pedigo et al. .
4,237,948	12/1980	Jones et al. .	4,781,591	11/1988	Allen .
4,258,716	3/1981	Sutherland .	4,790,303	12/1988	Steffee .
4,259,072	3/1981	Hirabayashi et al. .	4,805,602	2/1989	Puno et al. .
4,262,369	4/1981	Roux .	4,820,305	4/1989	Harms et al. .
4,271,832	6/1981	Evans et al. .	4,830,000	5/1989	Shutt .
4,289,123	9/1981	Dunn .	4,834,757	* 5/1989	Brantigan ..... 623/17
4,293,962	10/1981	Fuson .	4,848,327	7/1989	Perdue .
4,309,777	1/1982	Patil .	4,851,008	7/1989	Johnson .
4,328,593	5/1982	Sutter et al. .	4,863,476	9/1989	Shepperd .
4,333,469	6/1982	Jeffcoat et al. .	4,863,477	9/1989	Monson .
4,341,206	7/1982	Perrett et al. .	4,865,603	9/1989	Noiles .
4,349,921	9/1982	Kuntz .	4,877,020	10/1989	Vich .
4,356,572	11/1982	Guillemin et al. .	4,878,915	* 11/1989	Brantigan ..... 623/17
4,401,112	8/1983	Rezaian .	4,903,882	2/1990	Long .
4,405,319	9/1983	Cosentino .	4,911,718	3/1990	Lee et al. .
4,414,979	11/1983	Hirshorn et al. .	4,913,144	4/1990	Del Medico .
4,423,721	1/1984	Otte et al. .	4,936,848	* 6/1990	Bagby ..... 623/17
4,439,152	3/1984	Small .	4,943,291	7/1990	Tanguy .
4,450,834	5/1984	Fischer .	4,955,908	9/1990	Frey et al. .
4,484,570	11/1984	Sutter et al. .	4,957,495	9/1990	Kluger .
4,492,226	1/1985	Belykh et al. .	5,084,050	1/1992	Draenert .
4,497,320	2/1985	Nicholson et al. .	5,122,130	6/1992	Keller .
4,501,269	2/1985	Bagby .	5,484,437	* 1/1996	Michelson ..... 606/61
4,507,115	3/1985	Kambara et al. .	B1 4,232,679	11/1980	Schulman .
4,530,360	7/1985	Duarte .			

## FOREIGN PATENT DOCUMENTS

2076657	12/1981	(GB) .
2082754	3/1982	(GB) .
2126094	3/1984	(GB) .
2164277	3/1986	(GB) .
57-29348	2/1982	(JP) .
60-31706	2/1985	(JP) .
60-43984	3/1985	(JP) .
61-122859	6/1986	(JP) .
62-155846	7/1987	(JP) .
106 101	7/1939	(SE) .
1107854	8/1984	(SU) .
1124960	11/1984	(SU) .
1217374	3/1986	(SU) .
1222254	4/1986	(SU) .
84/01298	4/1984	(WO) .

## OTHER PUBLICATIONS

- Gillingham, F.J., et al.; Head injuries; Proceedings of the 18<sup>th</sup> World Congress of the International College of Surgeons, Rome, pp. 68–71 (May 28–31, 1972).
- Whatmore, W.J.; Sincipital Encephalomeningoceles; Brit. J. Surg., vol. 60, No. 4, pp. 261–270 (Apr. 1973).
- Whatmore, W.J.; Meningioma Following Trauma; Brit. J. Surg., vol. 60, No. 6, pp. 496–498 (Jun. 1973).
- Bagby, George W.; Wobbler Syndrome in Horses (the Ataxic Horse); Spokane County Medical Society Bulletin; Spring 1979.
- Rathke, F.W., et al.; Surgery of the Spine; Atlas of Orthopaedic Operations, vol. 1, p. 137, W.B. Saunders Co., Philadelphia (1979).
- Albrektsson, T., et al.; Osseointegrated Titanium Implants; Acta. Orthop. Scand.; vol. 52:155–170 (1981).
- Raveh, J., et al.; Neue Rekonstruktionsmöglichkeiten des Unterkiefers bei knöchernen Defekten nach Tumorsektionen; Der Chirurg vol. 53:459–467 (1982).
- Crock, H.V.; Practice of Spinal Surgery; Springer-Verlag/Wien, New York (1983).
- DeBowes, R.M., et al.; Study of Bovine...Steel Baskets; Transactions of the 29th Annual Meeting; Orthopaedic Research Society, vol. 8, p. 407, Mar. 8–10 (1983).
- O'Neill, P., et al.; Spinal Meningoceles in Association with Neurofibromatosis; Neurosurgery, vol. 13, No. 1, pp. 82–84 (Jul. 1983).
- Brandt, L., et al.; A Dowel Inserter for Anterior Cervical Interbody Fusion; J. Neurosurg. 61:793–794 (Oct. 1984).
- Whatmore, W.J., et al.; The Coventry Cervical Spreader and Dowel Inserter; ACTA Neurochirurgica, vol. 70, FASC. 1–2 (1984).
- Raveh, J., et al.; Use of the Titanium-coated Hollow Screw and Reconstruction Plate System in Bridging of Lower Jaw Defects; J. Oral Maxillofac Surg. 42:281–294 (1984).
- Otero-Vich, Jose M.; Anterior Cervical Interbody Fusion with Threaded Cylindrical Bone; J. Neurosurg 63:750–753 (Nov. 1985).
- Morscher, E., et al.; Die vordere Verplattung der Halswirbelsäule mit dem Hohlschrauben-Plattensystem aus Titanium, Der Chirurg, vol. 57, pp. 702–707 (1986) with English Translation.
- Bagby, G.W.; Basket Implant Facilitates Spinal Fusion; Orthopedics Today, vol. 7, No. 10, (Oct. 1987).
- Butts, M.K., et al.; Biomechanical Analysis of a New Method for Spinal Interbody Fixation; 1987 Symposium, American Society of Mechanical Engineers, "Advances in Bioengineering", Boston, MA (Dec. 13–18, 1987).
- Crawley et al.; A Modified Cloward's Technique for Arthrodesis of the Normal Metacarpophalangeal Joint in the Horse; Veterinary Surgery, vol. 17, No. 3, pp. 117–127 (1988).
- Raveh, J., et al.; Surgical Procedures for Reconstruction of the Lower Jaw Using the Titanium-Coated Hollow-Screw Reconstruction Plate System: Bridging of Defects; Otolaryngologic Clinics of North America; vol. 20, No. 3 (Aug. 1987).
- Whatmore, W.J.; Proceedings of the Society of British Neurological Surgeons; Journal of Neurology, Neurosurgery, and Psychiatry, 50:1093–1100 (1987).
- Goldthwaite, N., et al.; Toward Percutaneous Spine Fusion; Ch. 45; Lumbar Spine Surgery; C.V. Mosby Company, pp. 512–522 (1987).
- Bagby, G.W.; Arthrodesis by the Distraction-Compression Method Using a Stainless Steel Implant; Orthopedics, vol. II, No. 6, pp. 931–934 (Jun. 1987).
- Itoman, M., et al.; Banked Bone Grafting for Bone Defect Repair—Clinical Evaluation of Bone Union and Graft Incorporation; J. Jpn. Orthop. Assoc. 62:461–469 (1988).
- Kane, W.J.; Direct Current Electrical Bone Growth Stimulation for Spinal Fusion; Spine, vol. 13, NO. 3, pp. 363–365 (Mar. 1988).
- Codman & Shurtleff, Inc.; Neurosurgical Catalog; USS 20556–20945(1986).
- Codman; Surgical Instruments Catalog; USS 20073–20555; (1979).
- Yashon, David; Spinal Injury, Second Edition; Appleton-Century Crofts; pp. 245–258 (1986).

\* cited by examiner

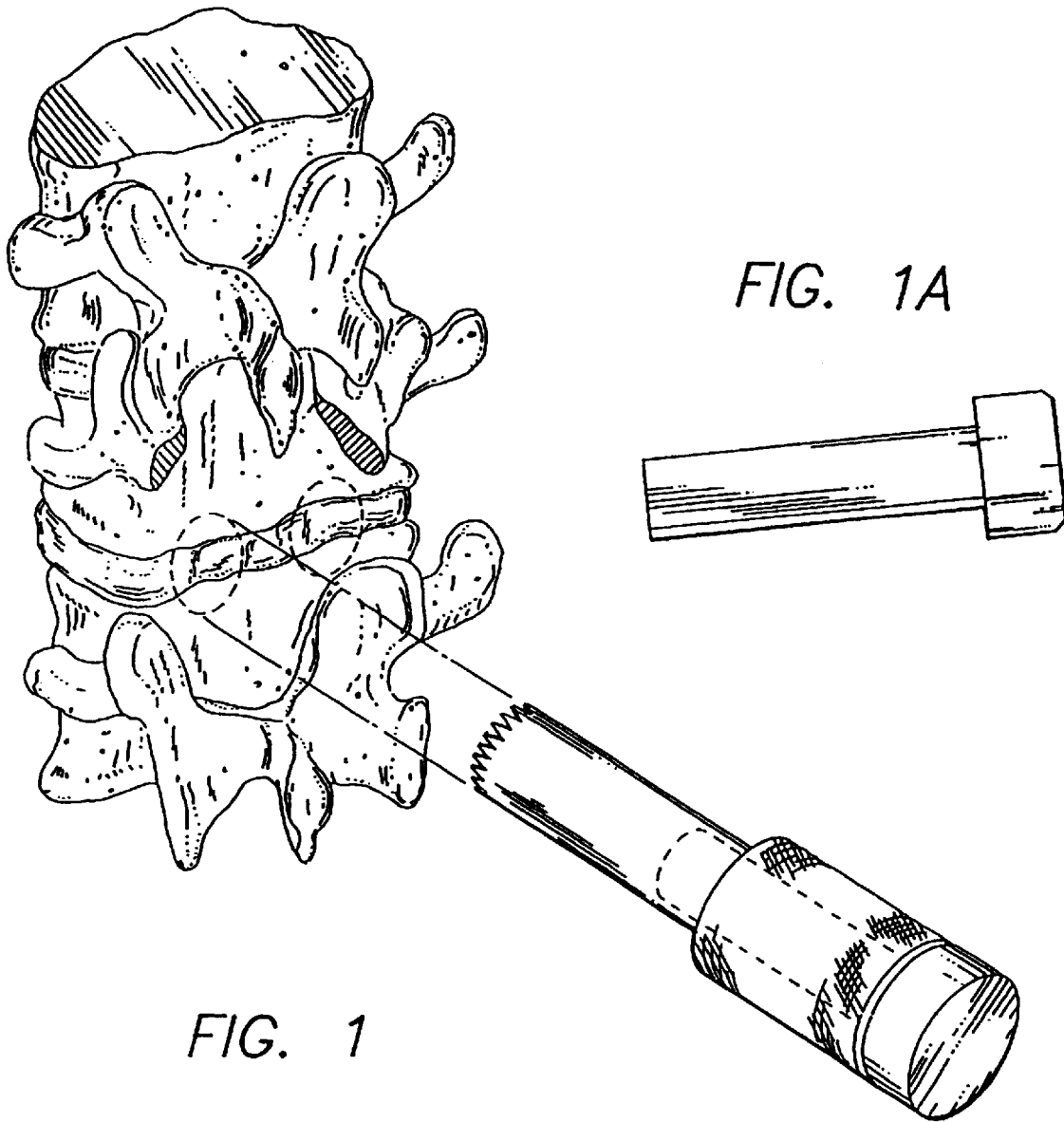
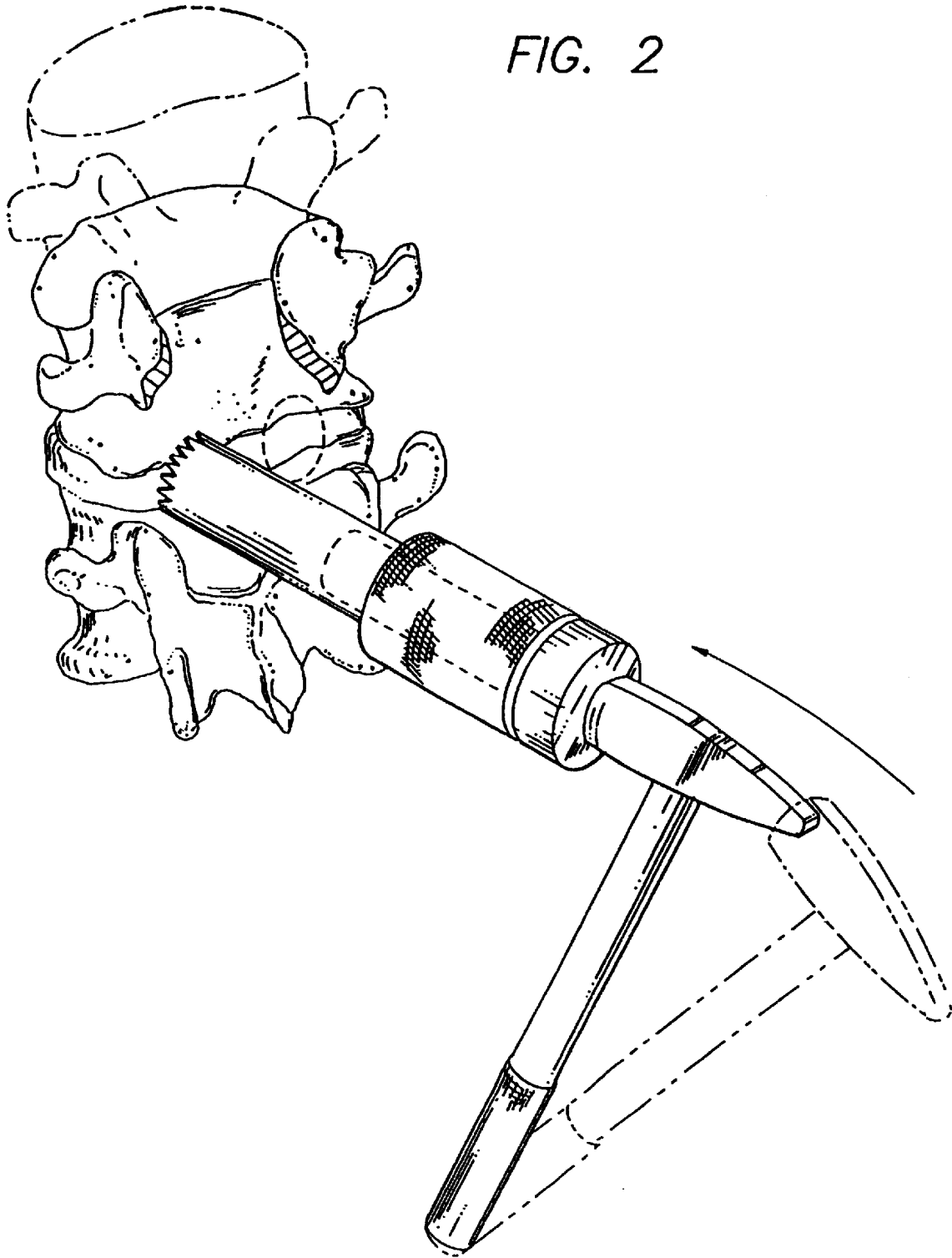
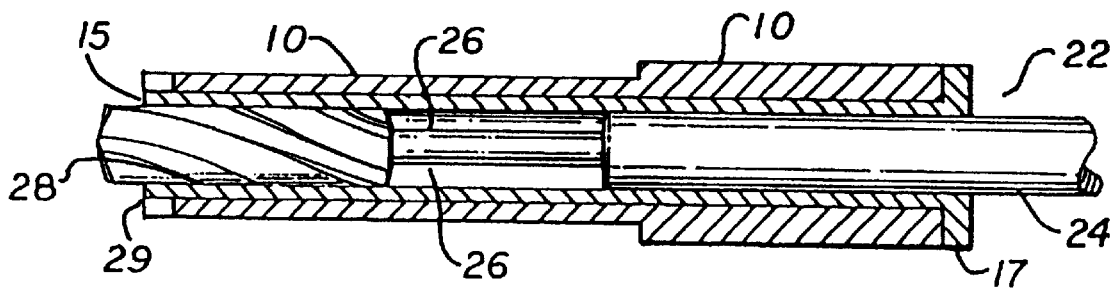
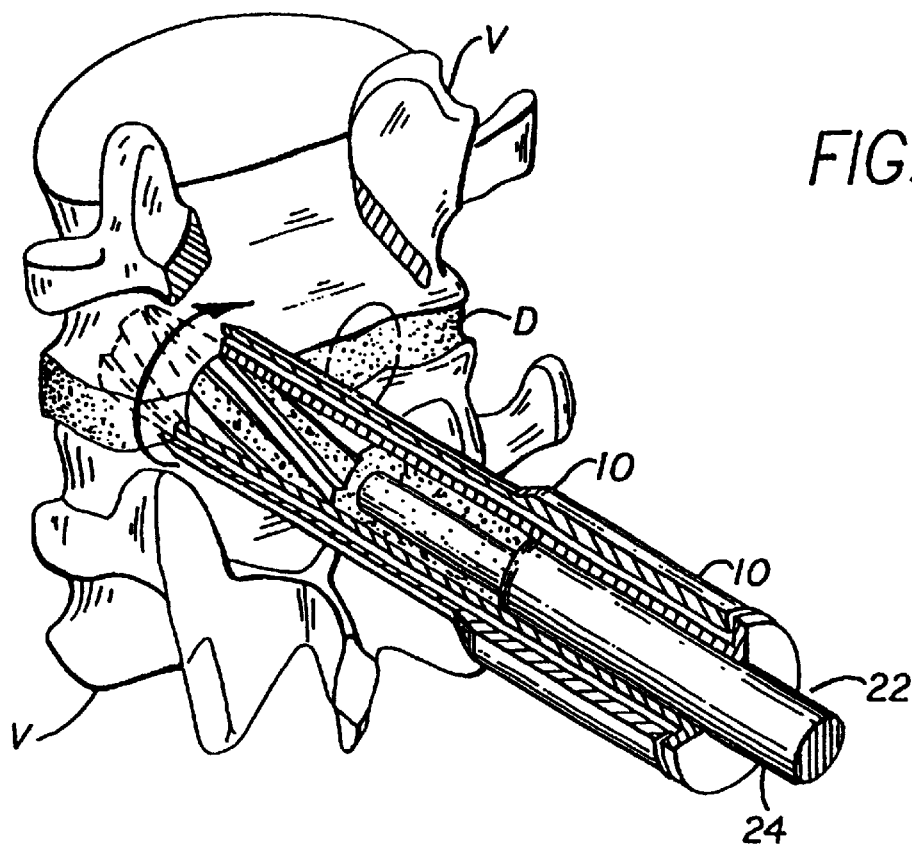

FIG. 1A

FIG. 1

FIG. 2





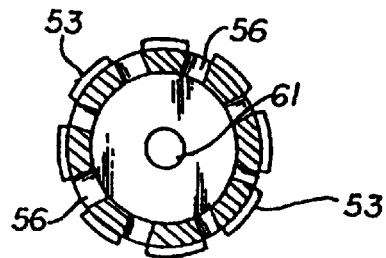
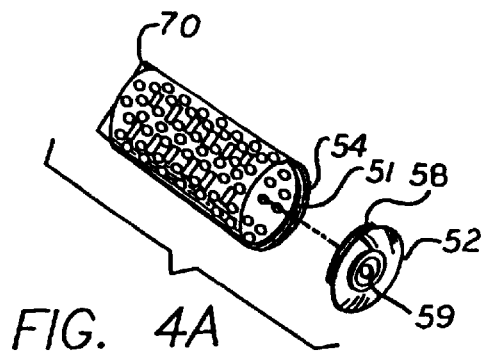
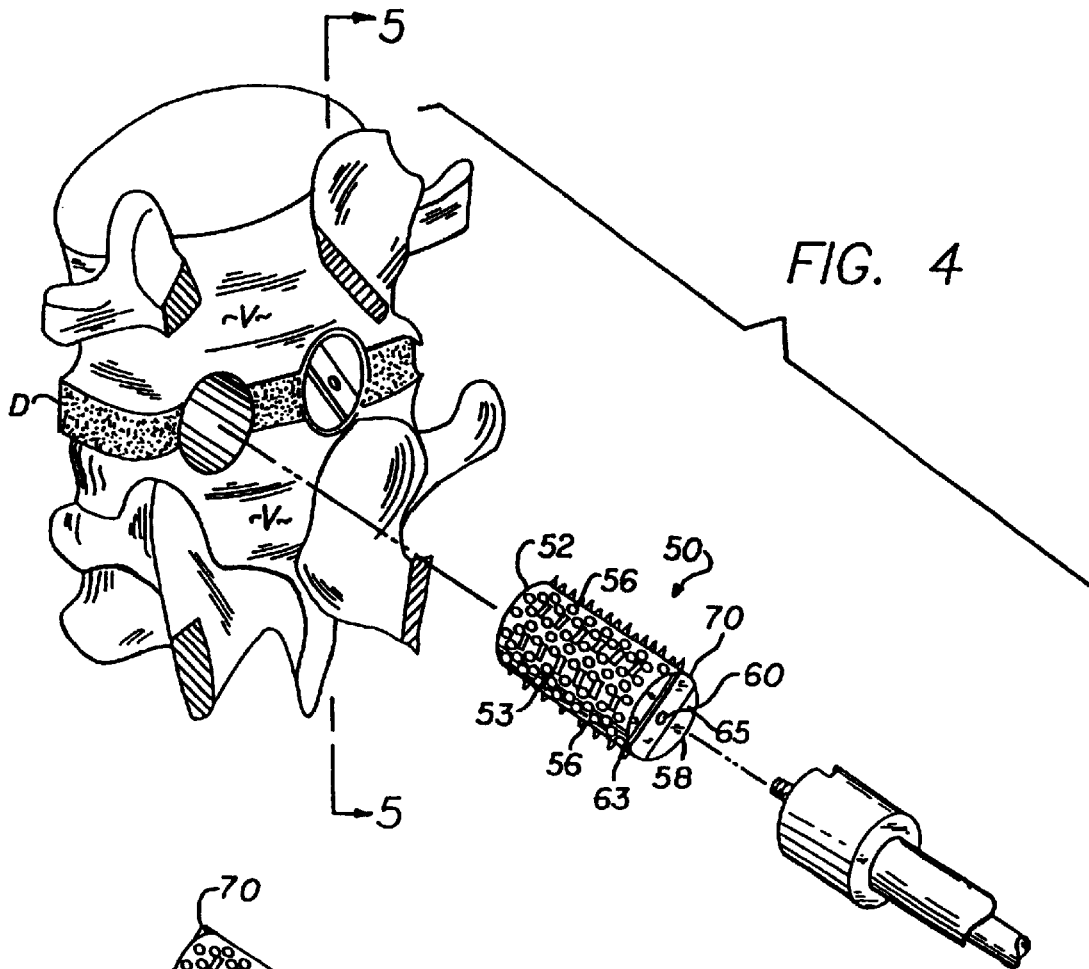

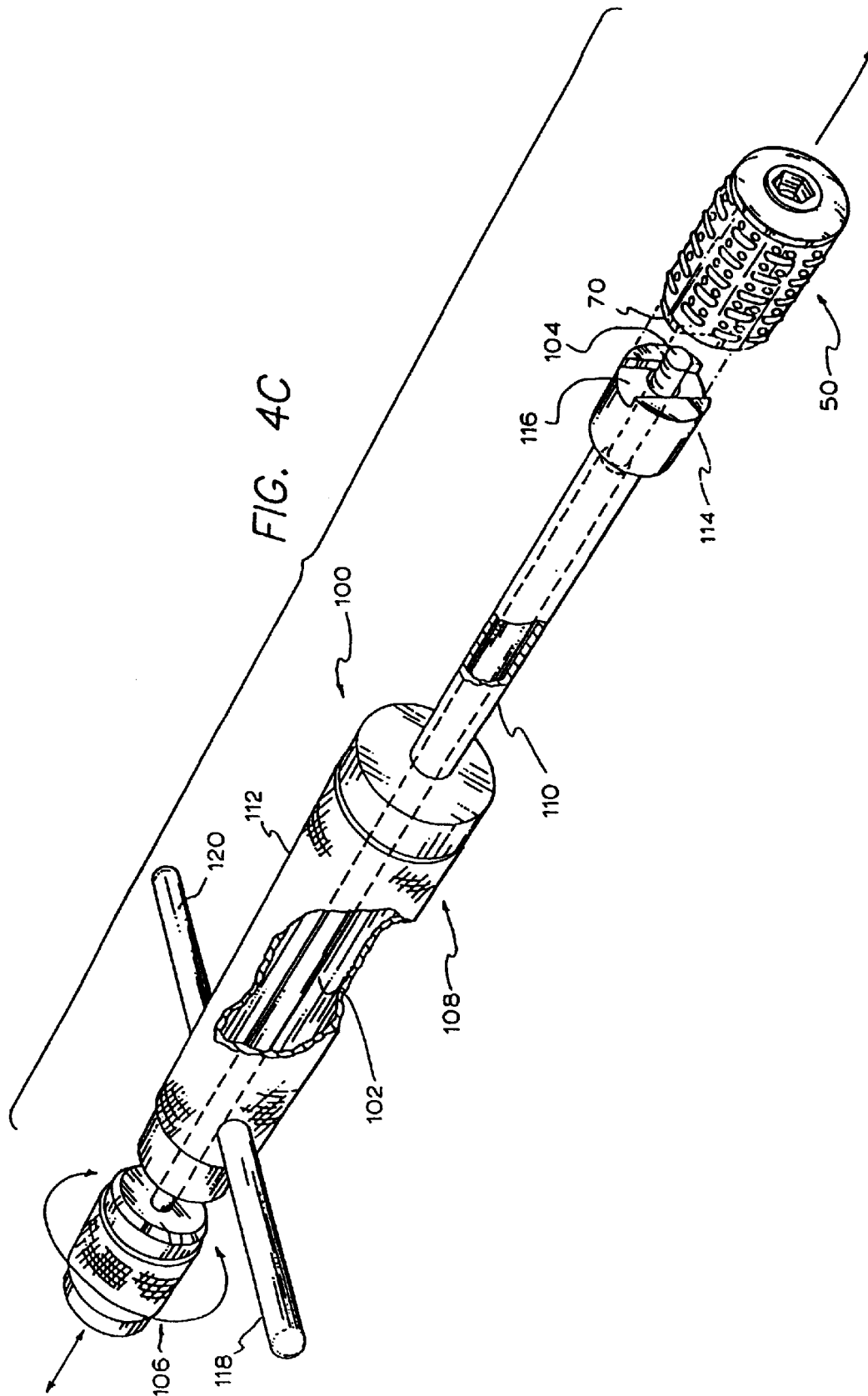



FIG. 4D

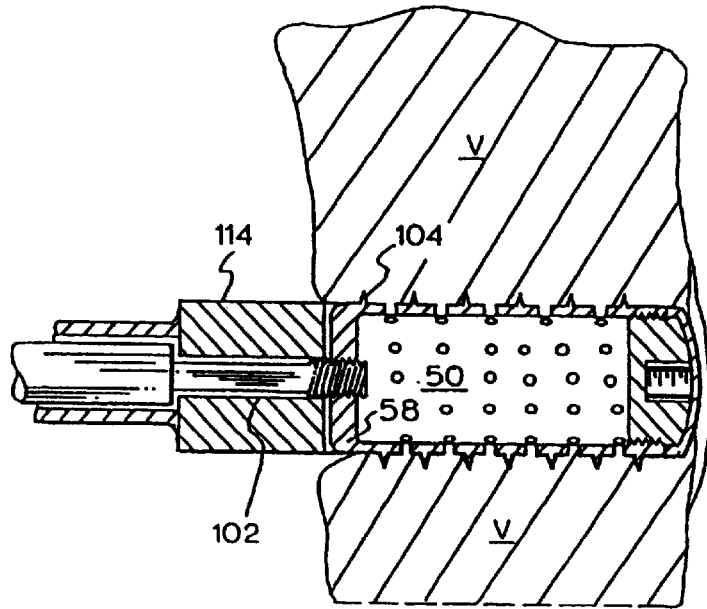
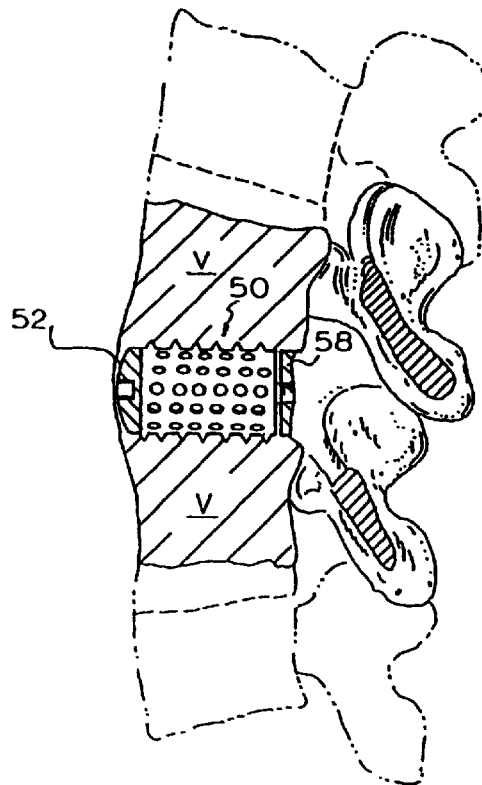

FIG. 5



## METHOD FOR INSERTING A SPINAL IMPLANT

### BACKGROUND

The present invention relates to an artificial fusion implant to be placed into the intervertebral space left after the removal of a damaged spinal disc.

The purpose of the present invention is to provide an implant to be placed within the intervertebral disc space and provide for the permanent elimination of all motion at that location. To do so, the device is space occupying within the disc space, rigid, self-stabilizing to resist dislodgement, stabilizing to the adjacent spinal vertebrae to eliminate local motion, and able to intrinsically participate in a vertebra to vertebra bony fusion so as to assure the permanency of the result.

At present, following the removal of a damaged disc, either bone or nothing is placed into the space left. Placing nothing in the space allows the space to collapse which may result in damage to the nerves; or the space may fill with scar tissue and eventually lead to a reherniation. The use of bone is less than optimal in that the bone obtained from the patient requires additional surgery and is of limited availability in its most useful form, and if obtained elsewhere, lacks living bone cells, carries a significant risk of infection, and is also limited in supply as it is usually obtained from accident victims. Furthermore, regardless of the source of the bone, it is only marginal structurally and lacks a means to either stabilize itself against dislodgement, or to stabilize the adjacent vertebrae.

A review of related prior art will demonstrate the novelty of the present invention.

There have been an extensive number of attempts to develop an acceptable disc prosthesis (an artificial disc). Such devices by design would be used to replace a damaged disc and seek to restore the height of the interspace and to restore the normal motion of that spinal joint. No such device has been found that is medically acceptable. This group of prosthetic or artificial disc replacements, seeking to preserve spinal motion and so are different from the present invention, would include:

U.S. Pat. No. 3,867,728 STUBSTAD—describing a flexible disc implant.

U.S. Pat. No. 4,349,921 KUNTZ—describing a flexible disc replacement with file like surface projections to discourage device dislocation.

U.S. Pat. No. 4,309,777 PATIL—describing a motion preserving implant with spiked outer surfaces to resist dislocation and containing a series of springs to urge the vertebrae away from each other.

U.S. Pat. No. 3,875,595 FRONING—describing a motion preserving bladder like disc replacement with two opposed stud-like projections to resist dislocation.

U.S. Pat. No. 2,372,622 FASSIO (FRENCH)—describing a motion preserving implant comprising complimentary opposed convex and concave surfaces.

In summary then, these devices resemble the present invention only in that they are placed within the intervertebral space following the removal of a damaged disc. In that they seek to preserve spinal motion, they are diametrically different from the present invention which seeks to permanently eliminate all motion at that spinal segment.

A second related area of prior art includes those devices utilized to replace essentially wholly removed vertebra. Such removal is generally necessitated by extensive verte-

bral fractures, or tumors, and is not associated with the treatment of disc disease. While the present invention is to be placed within the disc space, these other vertebral devices cannot be placed within the disc space as at least one vertebra has already been removed such that there no longer remains a “disc space.” Furthermore, these devices are limited in that they seek to perform as temporary structural members mechanically replacing the removed vertebra (not a removed disc), and do not intrinsically participate in supplying osteogenic material to achieve cross vertebrae bony fusion. Therefore, again unlike the present invention which provides for a source of osteogenesis, use of this group of devices must be accompanied by a further surgery consisting of a bone fusion procedure utilizing conventional technique. This group consisting of vertebral struts rather than disc replacements would include the following:

U.S. Pat. No. 4,553,273 WU—describing a turnbuckle like vertebral strut.

U.S. Pat. No. 4,401,112 REZAIAN—describing a turnbuckle like vertebral strut with the addition of a long stabilizing staple that spans the missing vertebral body.

U.S. Pat. No. 4,554,914 KAPP—describing a large retractible spike that elongates with a screw mechanism to span the gap left by the removal of a entire vertebra and to serve as an anchor for acrylic cement which is then used to replace the missing bone (vertebra).

U.S. Pat. No. 4,636,217 OGILVIE—describing a vertebral strut mechanism that can be implanted after at least one vertebra has been removed and which device consists of a mechanism for causing the engagement of screws into the vertebra above and the vertebra below the one removed.

In summary then, this group of devices differs from the present invention in that they are vertebra replacements struts, do not intrinsically participate in the bony fusion, can only be inserted in the limited circumstances where an entire vertebra has been removed from the anterior approach, and are not designed for, or intended to be used for the treatment of disc disease.

A third area of prior art related to the present invention includes all devices designed to be applied to one of the surfaces of the spine. Such devices include all types of plates, struts, and rods which are attached by hooks, wires and screws. These devices differ significantly from the present invention in that they are not inserted within the disc space, and furthermore do not intrinsically participate in supplying osteogenic material for the fusion.

Therefore, with these devices where permanent spinal immobilization is desired an additional surgery consisting of a spinal fusion performed by conventional means or the use of supplemental methylmethacrylate cement is required. Such devices applied to the spine, but not within the disc space, would include the following:

U.S. Pat. No. 4,604,995—STEPHENS—describing a “U” shaped metal rod attached to the posterior elements of the spine with wires to stabilize the spine over a large number of segments.

U.S. Pat. No. 2,677,369—KNOWLES—describing a metal column device to be placed posteriorly along the lumbar spine to be held in position by its shape alone and to block pressure across the posterior portions of the spinal column by locking the spine in full flexion thereby shifting the maximum weight back onto the patient’s own disc.

Other devices are simply variations on the use of rods (e.g. Harrington Luque, Cotrel-Dubosset, Zielke), wires or cables (Dwyer), plates and screws (Steffee), or struts (Dunn, Knowles).

In summary, none of these devices are designed or can be used within the disc space, do not replace a damaged disc, and do not intrinsically participate in the generation of a bony fusion.

Another area of related prior art to be considered is that of devices designed to be placed within the vertebral interspace following the removal of a damaged disc, and seeking to eliminate further motion at that location.

Such a device is contained in U.S. Pat. No. 4,501,269 BAGBY—describing an implantable device and limited instrumentation. The method employed is as follows: a hole is bored transversely across the joint and then a hollow metal basket of larger diameter than the hole is then pounded into the hole and then filled with the bone debris generated by the drilling.

While the present invention (device, instrumentation, and method) may appear to bear some superficial resemblance to the BAGBY invention, it is minimal, while the differences are many fold and highly significant. These differences include the following:

#### 1. Safety

The present invention provides for a system of completely guarded instrumentation so that all contiguous vital structures (e.g. large blood vessels, neural structures) are absolutely protected. Said instrumentation also makes overpenetration by the drill impossible. Such overpenetration in the cervical spine, for example, would result in the total paralysis or death of the patient. In the thoracic spine, the result would be complete paraplegia. In the lumbar spine, the result would be paraplegia or a life-threatening perforation of the aorta, vena cava, or iliac vessels. The present invention is atraumatically screwed into place while the BAGBY device, in contradistinction, is pounded into position. BAGBY describes that the implant is significantly larger in size than the hole drilled and must be pounded in. This is extremely dangerous and the pounding occurs directly over the spinal cord which is precariously vulnerable to percussive injury. Furthermore, while it is possible, for example in the lumbar spine, to insert the present invention away from the spinal cord and nerves, the BAGBY device must always be pounded directly towards the spinal cord.

Furthermore, since the BAGBY device is pounded into a smooth hole under great resistance, and lacking any specific design features to secure it, the device is highly susceptible to forceful ejection which would result in great danger to the patient and a clinical failure. The present invention, in contradistinction, is securely screwed into place, and possesses highly specialized locking threads to make accidental dislodgement impossible. Because of the proximity of the spinal cord, spinal nerves, and blood vessels, any implant dislodgement as might occur with the BAGBY device might have catastrophic consequences.

#### 2. Broad Applicability

The BAGBY device can only be inserted from the front of the vertebral column, however, the present invention can be utilized in the cervical, thoracic, and lumbar spine, and can be inserted from behind (posteriorly) in the lumbar spine. This is of great importance in that the purpose of these devices is in the treatment of disc disease and probably greater than 99 percent of all lumbar operations for the treatment of disc disease are performed from behind where the present invention can easily be utilized, but the BAGBY device, as per his description, cannot.

#### 3. Disc Removal

The BAGBY invention requires the complete removal of the disc prior to the drilling step, whereas the present invention eliminates the laborious separate process of disc

removal and efficiently removes the disc and prepares the vertebral end plates in a single step.

#### 4. Time Required

The present invention saves time over the BAGBY invention in that time is not wasted laboring to remove the disc prior to initiating the fusion. Also, since with the present invention the procedure is performed through a system of guarded instrumentation, time is not wasted constantly placing and replacing various soft tissue retractors throughout the procedure.

#### 5. Implant Stability

Dislodgement of the implant would be a major source of device failure (an unsuccessful clinical result), and might result in patient paralysis or even death. As discussed, the BAGBY device lacks any specific means of achieving stability and since it is pounded in against resistance to achieve vertebral distraction, it is susceptible to forceful dislodgement by the tendency of the two distracted vertebrae, to return to their original positions squeezing out the device. The present invention however is screwed into place. As there is no unscrewing force present between the vertebrae and compression alone cannot dislodge the implant, the implant is inherently stable by its design. Furthermore, the threads of the present invention are highly specialized in that they are periodically interrupted such that the tail ends of each of the Labs so formed are blunted and twisted so as to resist accidental unscrewing. The removal of an implant with such “locking threads” requires the use of a special extractor included within the instrumentation. The stability of the present invention is still further enhanced, again in contradistinction to the BAGBY device, by the presence of a “bone ingrowth” surface texturing, which both increases the friction of the fit and allows for the direct growth of the vertebral bone into the casing of the implant itself.

#### 6. Spinal Stability

The present invention is not only self-stabilizing, it also provides stability to the adjacent vertebrae in at least three ways that the BAGBY device cannot. First, the BAGBY device is placed transversely across the joint in the center, leaving both vertebrae free to rock back and forth over this round barrel shaped axis, much like a board over a barrel, being used for a seesaw.

Secondly, as the BAGBY device lacks any specific design features to resist sliding, it may actually behave as a third body allowing the translation of the vertebrae relative to the device and to each other.

Thirdly, any device can only provide stability if it remains properly seated. The present invention is inherently stable, and therefore assures that it will stabilize the adjacent vertebrae; rather than, as with the BAGBY device, where the instability of the spine to be treated may instead cause a dislocation of the implant, with further loss of spinal stability.

#### 7. The Collapse of the Interspace

While both the present invention and the BAGBY device can be fabricated to withstand the compression forces within the interspace, the interspace may nevertheless collapse under the superincumbent body weight as the implant settles into the vertebral bone. This is related to the load per unit area. Again the present invention is superior to the BAGBY device in at least four ways. First, the present invention offers considerably greater surface area to distribute the load. Secondly, while the BAGBY device is placed centrally, the present device is placed bilaterally where the bone tends to be more cortical and much stronger out towards the rim. Thirdly, the present invention supports the load achieving an

“I” beam effect, whereas the BAGBY implant does not. Fourthly, it is not pressure alone that causes the collapse of the bone adjacent to the implant, but also bony erosion that is caused by the motion under pressure of the implant against the bone. As discussed in item #6 above, the present invention alone is highly resistant to such motion, again diminishing the likelihood of erosion and interspace collapse.

#### 8. Bone Ingrowth Surface Texturing

The present invention has a surface treatment of known and conventional technology to induce the growth of bone from the vertebrae directly into the casing material of the implant itself. The BAGBY device has no similar feature.

#### 9. Fusion Mass

The BAGBY invention calls for removing the disc and then drilling a hole between the adjacent vertebrae. The bony debris so generated is then put into tie device. The present invention takes a core of pure bone producing marrow from the iliac crest, and then by use of a special press forcibly injects the device with an extremely dense compressed core of that osteogenic material until the material itself virtually extrudes from every cell of the implant.

#### 10. The Probability of Achieving Fusion

The fusion rate within the spine is known to be related directly to the amount of exposed vascular bone bed area, the quality and quantity of the fusion mass available, and the extent of the stabilization obtained with all other factors being held constant. It would then be anticipated, that the fusion rate would be superior with the present invention as compared to the BAGBY device, because of optimal implant stability (#5), optimal spinal stability (#6), bone ingrowth surface treatment (#8), superior fusion mass (#9), and the greater exposed vertebral bony surface area (#7).

The last area of prior art possibly related to the present invention and therefore, to be considered related to “BONY INGROWTH”, and patents either describe methods of producing materials and or materials or devices to achieve the same. Such patents would include:

U.S. Pat. No. 4,636,526 (DORMAN), No. 4,634,720 (DORMAN), No. 4,542,539 (ROWE), No. 4,405,319 (COSENTINO) No. 4,439,152 (SMALL), No. 4,168,326 (BROEMER), No. 4,535,485 (ASHMAN), No. 3,987,499 (SCHARBACH), No. 3,605,123 (HAHN), No. 4,655,777 (DUNN), No. 4,645,503 (LIN), No. 4,547,390 (ASHMAN), No. 4,608,052 (VAN KAMPEN), No. 4,698,375 (DORMAN), No. 4,661,536 (DORMAN), No. 3,952,334 (BOKROS), No. 3,905,047 (LONG), No. 4,693,721 (DUCHEYNE), No. 4,070,514 (ENTHERLY).

However, while the present invention would utilize bone ingrowth technology, it would do so with conventional technology.

In summary then, the present invention, instrumentation, and method, alone provides for a one stage discectomy, fusion, and interbody internal spinal fixation; that being performed more quickly, with greater safety, and more affectively, for all of the aforementioned reasons than is possible with any other known art.

#### BRIEF SUMMARY OF THE INVENTION

The present invention comprises a series of artificial implants, the purpose of which is to participate in, and directly cause bone fusion across an intervertebral space following the excision of a damaged disc. Such implants are structurally load bearing devices, stronger than bone, capable of withstanding the substantial forces generated within the spinal interspace. Such devices have a plurality of macro sized cells and openings, which can be loaded with fusion promoting materials, such as autogenous bone, for the

purpose of materially influencing the adjacent vertebrae to form a bony bond to the implants and to each other. The implant casing may be surface textured or otherwise treated by any of a number of known technologies to achieve a “bone ingrowth surface” to further enhance the stability of the implant and to expedite the fusion.

Further, said devices are so configured and designed so as to promote their own stability within the vertebral interspace and to resist being dislodged, and furthermore, to stabilize the adjacent spinal segments.

The apparatus for preparing the vertebrae for insertion of the implant is also disclosed, such instrumentation and method allowing for the rapid and safe removal of the disc, preparation of the vertebrae, performance of the fusion, and internal stabilization of the spinal segment.

#### DISCUSSION OF THE INSTRUMENTATION

The concept of performing various aspects of this surgery are not entirely new. Drills are frequently placed through hollow, tubular guards to protect the adjacent soft tissues. A set of instruments developed by Ralph Cloward utilizes such a tubular drill guard on a larger scale, for the purpose of drilling into the cervical spine. However, this inventor is unaware of any set of instruments, system, or procedure designed to allow the entire surgical procedure beyond the initial exposure, to be performed blindly and with complete safety through a fixed sheath apparatus. Specific design features which combine to make this uniquely possible are as follows:

1. The availability of the specific implant.
2. The end of all the penetrating instrumentation is blunt faced.
3. All of the instruments have been stopped out at a predetermined depth to avoid overpenetration.
4. The design of the external sheath conforms to the spacial limitations of the specific surgical site.
5. The design and use of a second or inner sheath allows for the difference in size between the inside diameter of the outer sheath, and the outside diameter of the drill itself. This difference being necessary to accommodate the sum of the distraction to be produced, and the depth of the circumferential threading present on the implant.
6. A specially designed drill bit with a central shaft recess allows for the safe collection of the drilling products, which can then be removed without disturbing the outer sheath by removing the drill bit and inner sheath as a single unit.
7. A specially designed trephine for removing a core of bone slightly smaller in diameter than the internal diameter of the implant cavity itself, however of a greater length.
8. A specially designed press for forcefully compressing and injecting the long core of autogenous bone into the implant, such that it extrudes through the implant itself.
9. A specially designed driver extractor, which attaches to the implant and allows the implant to be either inserted or removed without itself dissociating from the implant, except by the deliberate disengagement of the operator.

#### OBJECTS OF THE PRESENT INVENTION

It is an object of the present invention to provide an improved method of performing a discectomy, a fusion, and an internal stabilization of the spine, and specifically, all three of the above simultaneously and as a single procedure.

It is another object of the present invention to provide an improved method of performing a discectomy, a fusion, and

an internal stabilization of the spine, which is both quicker and safer than is possible by previous methods.

It is another object of the present invention to provide an improved method of performing a discectomy, a fusion, and an internal stabilization of the spine, to provide for improved surgical spinal implants.

It is another object of the present invention to provide an improved method of performing a discectomy, a fusion, and an internal stabilization of the spine, which provides for an improved system of surgical instrumentation to facilitate the performance of the combined discectomy, fusion, and internal spinal stabilization.

These and other objects of the present invention will be apparent from review of the following specifications and the accompanying drawings.

#### BRIEF DESCRIPTION OF THE DRAWINGS

FIG. 1 is a perspective view of the driver and sheath and its orientation to a vertebral structure.

FIG. 1A is a perspective view of the driver member for the outer sheath.

FIG. 2 is a perspective view of the outer sheath being inserted into the vertebrae structure.

FIG. 3 is a perspective view of the outer sheath and inner sheath assembly, with the drill bit of the present invention.

FIG. 3A is a side sectional view of the collar and drill bit of FIG. 3.

FIG. 4 is a perspective view of a cylindrical implant and vertebrae structure.

FIG. 4A is a perspective view of one preferred embodiment of the implant.

FIG. 4B is a cross sectional view of the implant of FIG. 4A.

FIG. 4C is the driving and insertion equipment for the implant of FIG. 4A.

FIG. 4d is a side sectional view of the driver and implant between vertebrae.

FIG. 5 is a sectional view of the vertebrae structure, taken along lines 5—5 of FIG. 4.

#### DETAILED DESCRIPTION OF THE DRAWINGS

Referring to FIG. 1 a vertebrae structure comprising two vertebrae V and a disc D between the two vertebrae, is shown. A hollow tubular drill sleeve 10 has teeth 12 at its lower end. The sleeve 10 has an enlarged diameter upper portion 14.

A driver 16, shown in FIG. 1A, consists of a solid tubular member 18 and an increased diameter head 20. The external diameter of the solid tubular member 18 is slightly smaller than the inside diameter of the hollow tubular drill sleeve 10 and has a length that is substantially shorter than the overall length of the hollow tubular drill sleeve 10.

The drill sleeve 10 is made of metal in order to be driven into the vertebrae V and be held in place by the teeth 12 of the drill sleeve 10.

Referring to FIG. 2 the drill sleeve 10 with the driver 16 installed is shown being driven into two vertebrae V on either side of a disc D by hammer H.

Referring to FIG. 3 and 3a the drill assembly is shown. In FIG. 3 the drill sleeve 10 is illustrated in the two vertebrae V, straddling the disc D.

The retaining sleeve 15 has an outside diameter slightly smaller than the inside diameter of the drill sleeve 10, and

a length substantially the same length as the drill sleeve 10. The retaining sleeve 15 has a collar 17 at its upper end for engaging the top of the drill sleeve 10.

The drill 22 comprises an upper portion 24, a central recessed portion 26 and a lower cutting drill portion 28. The upper 24 and lower portion 28 of the drill 22 have the same outside diameter. The drill 24 has a collar 30 attached to the upper portion 24 of the drill 22.

The outside diameter of the drill 22 is slightly smaller than the inside diameter of the retaining sleeve 15. The length of the drill, from the collar 30 to the end of the drill bit, is such that a predetermined portion of the drill bit 22 extends beyond the end 29 of the sleeve when fully inserted.

Referring to FIG. 4, a cylindrical embodiment of the present invention is shown, one implant positioned in the opening in the vertebrae and disc formed by the drill 22, and a second implant shown prior to implantation.

The cylindrical implant 50 comprises a hollow tubular member which in the preferred embodiment is made of an ASTM surgically implantable material, and preferably Titanium. The cylindrical implant 50 is closed at one end 52 and open at the other end 54. The outer cylindrical implant 50 has a series of macro-sized openings 56 through the side walls of the cylindrical member 50. A series of external threads 53 are formed on the circumference of the cylindrical implant 50. The threads 53 are locking threads having a series of interjections, the ends of which are blunted and twisted so as to resist unscrewing.

The open end 54 of the cylindrical implant 50 has an internal thread 51 for receiving a complementary cap 82 which has an external thread 58 for engaging the internal threads 51 of the cylindrical member 50. The cap 52 has a hexagonal opening 59 for use with an allen wrench for tightening the cap. A driver engaging element 70 is located on the rear surface 60 of the implant. The driver engaging element 70 comprises a raised rectangular portion 63 and a central threaded opening 65, for engaging the driver apparatus, shown in FIG. 4c and FIG. 4d. The driving equipment 100 comprises a central tubular rod 102 having a thread fitting into opening 65 in the implant. An enlarged knurled knob 106 is affixed to the other end of the rod 102 for ease in turning. The central rod 102 is enclosed within a hollow tubular member 108, having a narrow lower portion 110 and an increased diameter upper portion 112. At the end of the lower portion 110 is an attachment member 114, having a generally rectangular depression 116 for complementing the driver engaging element 70 of the implant 50. A pair of handles 118 and 120 extend perpendicular from the upper position 112 of the tubular member 108 to assist in turning the driver 100.

An embodiment of the method of the present invention comprises the steps of inserting a tubular member into the vertebrae, removing the disc and a portion of the adjacent vertebrae through the tubular member, inserting an implant into the vertebrae through the tubular member, and then removing the tubular member.

The operation is performed in the following manner: (Example Lumbar Spine Posterior Approach) A skin incision is made directly over one interspace to be operated on. The dissection is carried down along side of the supraspinous and interspinous ligaments preserving those structures. A semi hemi laminotomy is performed at the upper level, removing sufficient bone to allow access into the interspace. The ligament flavum is removed and then the dural sac is protected by retracting it medially along with the traversing (inferior) nerve root. The superior nerve root or the root exiting beneath the pedicle at the level above is visualized and protected.

At this time the drill sleeve **10** is placed into the spinal canal with both nerve roots directly inspected and protected. The drill sleeve **10** is imbedded by teeth **12** spanning the disc space from the midline over and it is seated into the two vertebrae **V** across the disc **D** space by using a driver **20**. Once this is done, the driver **20** is removed and a retaining sleeve **15** is placed through the drill sleeve **10**. Once seated, sleeve **10** provides absolute protection to the dural sac and nerve roots as the remaining surgery is performed entirely through this sleeve.

The inner sleeve allows for the difference between the outside diameter of the drill **22** and the outside diameter of the threads **53** of the cylindrical implant **50**. This then makes it possible to perform the entire operation through the end of the imbedded outer sleeve despite the differences in diameter between the drill and the implant.

A drill **22** is then placed in the retaining sleeve **17**. The drill **22** is of such a length that it can not penetrate more than 28 millimeters beyond the end of the drill sleeve **10**. This, of course, could be varied and made smaller for enhanced safety. However at the present time 27 to 28 millimeters seems to be safe for probably 3 standard deviations of the population. The drill **22** is attached to a power unit and the drilling takes place.

The recessed central area between the reduced portion **26**, allows for the accumulation of the debris generated by the drilling. At this time, leaving the outer sleeve firmly embedded, the retaining sleeve **17** is removed with the drill **22** as a single unit. All the vertebrae and disc debris that was generated during the drilling is contained within the recess and against the inside wall of the retaining sleeve **17** and can not come out within the spinal canal. Once the retaining sleeve **17** and drill **22** is out of the patient's operative field, all of the material so generated can be removed.

The next step is that a screw tap is put down through the drill sleeve **10**. The tap also has a collar on it that will automatically stop the tap from extending beyond 28 millimeters of penetration. The tap itself has a blunt nose that would also avoid any perforation. The tap is then removed. The tap size has deliberately been selected so that its inner root diameter is 1.3 millimeters greater than the outside diameter of the drill **22**. This insures that the interspace will be distracted by at least that much once the implant is placed. The tap has its outside diameter 1.2 millimeters greater than its root diameter. The tap is removed and the space is now prepared to accept the cylindrical implant **50**.

The Implant **50** is prepared by utilizing the trephine, a hollow drill, to obtain a core of pure cancellous bone from the patients iliac crest of slightly smaller diameter than the internal diameter of the implant but approximately 6 mm longer. The implant **50** is placed in a press lice device like an ammo loader and the bone graft measuring approximately 32 millimeters is then compressed into the hollow body of the implant (26 mm) so that the bone graft fills the opening **54** and extends through the openings **56**. The cap **60** is then screwed on to the implant **50** by use of an alien driver/wrench and the device is ready for implantation.

The inserter/remover is such that it locks onto the implant, so that the implant can be moved either clockwise or counter-clockwise, screwed or unscrewed. The implant itself has for its root diameter the same exact root diameter as the tap which as already noted is already 1.3 millimeters greater than the drill and has an outside diameter, 1.5 millimeters greater than its root. This is also 0.3 millimeters greater than the threads cut by the tap so that in inserting the device it is actually cutting through previously uncut bone helping to

insure that it locks in firmly. The threads on the implant **50** are locking threads so that it is easier to screw the device in than for it to be unscrewed. However, with sufficient torque it is possible to extract the device if ones so desires.

Once the implant has been seated it is able to be inserted only 28 millimeters. Since the implant **50** is only 26 millimeters in length, this virtually guarantees that the implant **50** will be recessed into the vertebral bodies more than 2 millimeters and can not protrude into the spinal canal.

Similarly, the implants shown in FIG. **4b** can be implanted. The implant in FIG. **4b** is a modified solid, having extensive channelling throughout, and has no cap. A central opening **61** permits insertion of the bone graft material into the interior of the implant.

These implants have a surface configuration such as to induce bone ingrowth through the implant, and into the wall of the vertebrae in effect inducing fusion from one vertebrae in joint to the other, thereby eventually making the implant itself superfluous as the bone would do the work.

The implant itself, because of its being made of stronger material than bone, would provide structural support to the two vertebrae while awaiting bone ingrowth. Once the bone ingrowth occurred, however, the implant would be firmly and permanently fixed in place.

As shown in FIG. **4**, more than one implant is inserted into the disc space, thereby preventing the rocking motion that would result in the difficulties referred to above in the discussion of the Bagby patent.

While the invention has been described with regards to the preferred embodiment, it is recognized that alternative embodiment may be devised which would not depart from the present invention.

What I claim is:

1. A method for preparing two adjacent vertebrae and a disc space therebetween to receive at least one implant, the method consisting essentially of the steps of:

positioning one end of a hollow guard in contact with the adjacent vertebrae;

removing, through said hollow guard, bone from the adjacent vertebrae to form an opening across the disc space and into a portion of each of the two adjacent vertebrae; and

inserting said implant having a height greater than the normal height of the disc space through said hollow guard and into the opening.

2. The method of claim 1, wherein the positioning step includes the step of engaging said one end of said hollow guard to the two adjacent vertebrae.

3. The method of claim 1, wherein the removing step includes the substep of milling the opening.

4. The method of claim 1, wherein the removing step includes the substep of drilling the opening.

5. The method of claim 1, wherein the inserting step includes the substep of screwing said implant into the opening through said hollow guard.

6. The method of claim 1, wherein the inserting step includes inserting said implant comprising a fusion-promoting substance.

7. The method of claim 1, further comprising the step of loading said implant with fusion-promoting material prior to the step of inserting.

8. The method of claim 1, wherein the positioning step includes the substep of positioning said guard having at least two projections extending distally from a distal end of said guard, said distal end adapted to contact each of the vertebrae adjacent the disc space to be fused, said at least two

projections adapted to penetrate the disc space so as to be located at least in part between the endplates of the vertebrae.

9. The method of claim 1, wherein the positioning step includes the step of positioning one end of a guard in contact with the adjacent vertebrae of the posterior lumbar spine, said guard for providing protected access to the spinal disc and the adjacent vertebrae to prepare across the spinal disc and into the adjacent vertebrae the implantation space and to insert into the implantation space said spinal implant through said guard, said guard having a passage through which said spinal implant passes into the implantation space in the spine, said guard having a distal end configured to be placed against the adjacent vertebrae, said distal end having a first portion adapted to be placed in contact with one of the adjacent vertebrae and a second portion adapted to be placed in contact with the other of the adjacent vertebrae, said first and second portions having a fixed height therebetween.

10. The method of claim 1, wherein the method is performed without distracting the adjacent vertebrae between the removing step and the inserting step.

11. The method of claim 1, wherein the method is performed without removing the hollow guard between the positioning step and the inserting step.

12. A method for preparing two adjacent vertebrae and a disc space therebetween to receive at least one implant, the method consisting essentially of the steps of:

positioning one end of a hollow guard in contact with the adjacent vertebrae;

forming, through said hollow guard, an opening across the disc space and into a portion of each of the two adjacent vertebrae, said opening having at least one arcuate portion extending into at least one of the adjacent vertebrae; and

inserting said implant through said hollow guard and into the opening.

13. The method of claim 12, wherein the positioning step includes the step of engaging said one end of said hollow guard to the two adjacent vertebrae.

14. The method of claim 12, wherein the forming step includes the substep of milling the opening.

15. The method of claim 12, wherein the forming step includes the substep of drilling the opening.

16. The method of claim 12, wherein the inserting step includes the substep of screwing said implant into the opening through said hollow guard.

17. The method of claim 12, wherein the inserting step includes inserting said implant comprising a fusion-promoting substance.

18. The method of claim 12, further comprising the step of loading said implant with fusion-promoting material prior to the step of inserting.

19. The method of claim 12, wherein the positioning step includes the substep of positioning said guard having at least two projections extending distally from a distal end of said guard, said distal end adapted to contact each of the vertebrae adjacent the disc space to be fused, said at least two projections adapted to penetrate the disc space so as to be located at least in part between the endplates of said vertebrae.

20. The method of claim 12, wherein the positioning step includes the step of positioning one end of a guard in contact with the adjacent vertebrae of the posterior lumbar spine, said guard for providing protected access to the spinal disc and the adjacent vertebrae to prepare across the spinal disc and into the adjacent vertebrae the implantation space and to insert into the implantation space said spinal implant

through said guard, said guard having a passage through which said spinal implant passes into the implantation space in the spine, said guard having a distal end configured to be placed against the adjacent vertebrae, said distal end having a first portion adapted to be placed in contact with one of the adjacent vertebrae and a second portion adapted to be placed in contact with the other of the adjacent vertebrae, said first and second portions having a fixed height therebetween.

21. The method of claim 12, wherein the method is performed without distracting the adjacent vertebrae between the forming step and the inserting step.

22. The method of claim 12, wherein the method is performed without removing the hollow guard between the positioning step and the inserting step.

23. A method for preparing two adjacent vertebrae and a disc space therebetween to receive at least one implant, the method comprising the steps of:

positioning one end of a hollow guard in contact with the adjacent vertebrae;

removing, through said hollow guard, bone from the adjacent vertebrae to form an opening across the disc space and into a portion of each of the two adjacent vertebrae; and

inserting said implant having a height greater than the normal height of the disc space through said hollow guard and into the opening, the method being performed without distracting the adjacent vertebrae between the removing step and the inserting step.

24. The method of claim 23, further comprising the step of providing a spinal fusion implant of a material suitable for human implantation having a height along the longitudinal axis of the spine greater than the height of the implantation space comprising upper and lower portions adapted for placement in contact each of the adjacent vertebrae when inserted in the implantation space, each of said upper and lower portions having at least one opening adapted for placement in contact with the adjacent vertebrae, respectively, said openings of said upper and lower portions being in communication with one another and adapted for permitting for the growth of bone from adjacent vertebra to adjacent vertebra through said implant; and

wherein the positioning step includes the step of positioning one end of a guard in contact with the adjacent vertebrae of the posterior lumbar spine, said guard for providing protected access to the spinal disc and the adjacent vertebrae to prepare across the spinal disc and into the adjacent vertebrae the implantation space and to insert into the implantation space said spinal implant through said guard, said guard having a passage through which said spinal implant passes into the implantation space in the spine, said guard having a distal end configured to be placed against the adjacent vertebrae, said distal end having a first portion adapted to be placed in contact with one of the adjacent vertebrae and a second portion adapted to be placed in contact with the other of the adjacent vertebrae, said first and second portions having a fixed height therebetween.

25. The method of claim 24, wherein the providing step includes the substep of providing said implant having at least a portion of said upper and lower portions that are arcuate along at least a portion of the length of said implant.

26. The method of claim 25, wherein the providing step includes the substep of providing said implant further comprising a hollow between said upper and lower arcuate portions of said implant for holding bone growth promoting material, said at least one opening of each of said upper and

lower portions of said implant are in communication with said hollow to permit bone from adjacent vertebrae to grow through said implant.

27. The method of claim 26, further comprising the step of loading said hollow interior of said implant with fusion promoting substances.

28. The method of claim 27, wherein the loading step includes the substep of loading said hollow interior of said implant with bone.

29. The method of claim 26, wherein the providing step includes the substep of providing said implant having at least one of an insertion end and a trailing end that is open and adapted for loading bone growth promoting substances into said hollow.

30. The method of claim 29, further comprising the step of engaging an end cap for closing said open end of said implant.

31. The method of claim 24, wherein the providing step includes the substep of providing said implant that is comprised at least in part of an implant material other than bone.

32. The method of claim 24, wherein the providing step includes the substep of providing said implant having said upper and lower portions having at least one protrusion on said upper and lower portions for engaging the adjacent vertebrae.

33. The method of claim 32, wherein said protrusion is at least a portion of a thread.

34. The method of claim 24, wherein the positioning step includes the substep of positioning said guard having projections projecting distally from said distal end for penetrably engaging the posterior surface of each of the adjacent vertebrae.

35. The method of claim 34, wherein said projections extend at least in part into the disc space.

36. The method of claim 34, wherein the positioning step includes the substep of positioning said guard further comprising a wall surrounding said passage, said projections being coextensive with said wall.

37. The method of claim 34, wherein the positioning step includes the substep of positioning said guard having at least two projections extending distally from said distal end of said guard, said distal end adapted to contact each of the vertebrae adjacent the disc space to be fused, said at least two projections adapted to penetrate the disc space so as to be located at least in part between the endplates of said vertebrae.

38. The method of claim 37, wherein said projections are at least in part co-linear with an outer perimeter of said guard.

39. The method of claim 38, wherein said projections are teeth.

40. The method of claim 37, wherein said projections are teeth being at least in part co-linear with an outer perimeter of said guard.

41. The method of claim 24, wherein the positioning step includes the substep of positioning said guard that is a tubular sleeve that is at least in part hollow.

42. The method of claim 24, wherein the positioning step includes the substep of positioning said guard having a length defined by a distal portion and a proximal portion forming said length, said guard having a substantially uniform cross section along its distal portion.

43. The method of claim 24, wherein the positioning step includes the substep of positioning said guard having a substantially uniform cross section along its length.

44. The method of claim 43, wherein said distal end of said guard has a cross sectional configuration substantially the same as said substantially uniform cross section of said guard.

45. The method of claim 24, wherein the positioning step includes the substep of positioning said guard having a distal end having a circumference that is uninterrupted and constant.

46. The method of claim 45, further comprising projections extending from said uninterrupted and constant circumference of said distal end of said guard for engaging the spine.

47. The method of claim 46, wherein said projections penetrate the disc space.

48. The method of claim 24, wherein the positioning step includes the substep of positioning said guard having a width measured perpendicular to its height, the width of said guard when appropriately selected being less than one half of the width of the disc space.

49. The method of claim 24, further comprising the step of tapping the opening through said hollow guard.

50. The method of claim 24, wherein the inserting step includes the substep of screwing said implant into the opening through said hollow guard.

51. The method of claim 24, wherein the providing step includes the substep of providing said implant having at least one of an insertion end and a trailing end, said trailing end being adapted to cooperatively engage a driver for inserting said implant through said hollow guard and into the opening.

52. The method of claim 23, wherein the positioning step includes the substep of positioning said guard having projections projecting distally from a distal end for penetrably engaging the surface of each of the adjacent vertebrae.

53. The method of claim 52, wherein said projections extend at least in part into the disc space.

54. The method of claim 52, wherein the positioning step includes the substep of positioning said guard further comprising a wall surrounding a passage, said projections being coextensive with said wall.

55. The method of claim 52, wherein the positioning step includes the substep of positioning said guard having at least two projections extending distally from a distal end of said guard, said distal end adapted to contact each of the vertebrae adjacent the disc space to be fused, said at least two projections adapted to penetrate the disc space so as to be located at least in part between the endplates of the vertebrae.

56. The method of claim 23, wherein the method is performed without removing the hollow guard between the positioning step and the inserting step.

57. A method for preparing two adjacent vertebrae and a disc space therebetween to receive at least one implant, the method comprising the steps of:

positioning one end of a hollow guard in contact with the adjacent vertebrae;

forming, through said hollow guard, an opening across the disc space and into a portion of each of the two adjacent vertebrae, said opening having at least one arcuate portion extending into at least one of the adjacent vertebrae; and

inserting said implant through said hollow guard and into the opening, the method being performed without distracting the adjacent vertebrae between the removing step and the inserting step.

58. The method of claim 57, wherein the positioning step includes the substep of positioning said guard having at least two projections extending distally from a distal end of said guard, said distal end adapted to contact each of the vertebrae adjacent the disc space to be fused, said at least two projections adapted to penetrate the disc space so as to be located at least in part between the endplates of said vertebrae.



59. The method of claim 57, wherein the positioning step includes the step of positioning one end of said guard in contact with the adjacent vertebrae of the posterior lumbar spine, said guard for providing protected access to the spinal disc and the adjacent vertebrae to prepare across the spinal disc and into the adjacent vertebrae the implantation space and to insert into the implantation space said spinal implant through said guard, said guard having a passage through which said spinal implant passes into the implantation space in the spine, said guard having a distal end configured to be placed against the adjacent vertebrae, said distal end having a first portion adapted to be placed in contact with one of the adjacent vertebrae and a second portion adapted to be placed in contact with the other of the adjacent vertebrae, said first and second portions having a fixed height therebetween.

60. The method of claim 57, wherein the method is performed without removing said hollow guard between the positioning step and the inserting step.

61. A method for preparing two adjacent vertebrae and a disc space therebetween to receive at least one implant, the method comprising the steps of:

positioning one end of a hollow guard in contact with the adjacent vertebrae;

removing, through said hollow guard, bone from the adjacent vertebrae to form an opening across the disc space and into a portion of each of the two adjacent vertebrae; and

screwing said implant having an external thread and a height greater than the normal height of the disc space through said hollow guard and into the opening.

62. The method of claim 61, wherein the positioning step includes the substep of positioning said guard having at least two projections extending distally from a distal end of said guard, said distal end adapted to contact each of the vertebrae adjacent the disc space to be fused, said at least two projections adapted to penetrate the disc space so as to be located at least in part between the endplates of the vertebrae.

63. The method of claim 62, wherein the positioning step includes the step of positioning one end of said guard in contact with the adjacent vertebrae of the posterior lumbar spine, said guard for providing protected access to the spinal disc and the adjacent vertebrae to prepare across the spinal disc and into the adjacent vertebrae the implantation space and to insert into the implantation space said spinal implant through said guard, said guard having a passage through which said spinal implant passes into the implantation space in the spine, said guard having a distal end configured to be placed against the adjacent vertebrae, said distal end having a first portion adapted to be placed in contact with one of the adjacent vertebrae and a second portion adapted to be placed in contact with the other of the adjacent vertebrae, said first and second portions having a fixed height therebetween.

64. The method of claim 61, wherein the method is performed without distracting the adjacent vertebrae between the removing step and the inserting step.

65. The method of claim 61, wherein the method is performed without removing said guard between the positioning step and the screwing step.

66. A method for preparing two adjacent vertebrae and a disc space therebetween to receive an implant, the method comprising the steps of:

anchoring one end of a substantially tubular member against the two adjacent vertebrae so that at least a portion of said one end of said tubular member extends at least in part between the adjacent vertebrae and into the disc space;

forming through said tubular member, an opening across the disc space and into a portion of each of the two adjacent vertebrae;

tapping the opening to provide threads over at least a portion of the vertebrae; and

screwing said implant through said tubular member and into the opening.

67. The method of claim 66, further comprising the step of providing a spinal fusion implant of a material suitable for human implantation having a height along the longitudinal axis of the spine greater than the height of the implantation space, comprising upper and lower portions adapted for placement in contact with each of the adjacent vertebrae when inserted in the implantation space, each of said upper and lower portions having at least one opening adapted for placement in contact with the adjacent vertebrae, respectively, said openings of said upper and lower portions being in communication with one another and adapted for permitting for the growth of bone from adjacent vertebra to adjacent vertebra through said implant; and

wherein the anchoring step includes the step of anchoring one end of said tubular member in contact with the adjacent vertebrae of the posterior lumbar spine, said tubular member for providing protected access to the spinal disc and the adjacent vertebrae to prepare across the spinal disc and into the adjacent vertebrae the implantation space and to insert into the implantation space said spinal implant through said tubular member, said tubular member having a passage through which said spinal implant passes into the implantation space in the spine, said tubular member having a distal end configured to be placed against the adjacent vertebrae, said distal end having a first portion adapted to be placed in contact with one of the adjacent vertebrae and a second portion adapted to be placed in contact with the other of the adjacent vertebrae, said first and second portions having a fixed height therebetween.

68. The method of claim 67, wherein the providing step includes the substep of providing said implant having at least a portion of said upper and lower portions that are arcuate along at least a portion of the length of said implant.

69. The method of claim 68, wherein the providing step includes the substep of providing said implant further comprising a hollow between said upper and lower arcuate portions of said implant for holding bone growth promoting material, said at least one opening of each of said upper and lower surfaces of said implant are in communication with said hollow to permit bone from adjacent vertebrae to grow through said implant.

70. The method of claim 69, further comprising the step of loading said hollow interior of said implant with fusion promoting substances.

71. The method of claim 70, wherein the loading step includes the substep of loading said hollow interior of said implant with bone.

72. The method of claim 71, wherein the anchoring step includes the substep of anchoring said tubular member that is a tubular sleeve that is at least in part hollow.

73. The method of claim 72, wherein the providing step includes the substep of providing said implant having at least one of an insertion end and a trailing end that is open and adapted for loading bone growth promoting substances into said hollow.

74. The method of claim 73, further comprising the step of engaging an end cap for closing said open end of said implant.

75. The method of claim 67, wherein the providing step includes the substep of providing said implant that is comprised at least in part of an implant material other than bone.

76. The method of claim 67, wherein the providing step includes the substep of providing said implant having said upper and lower portions having at least one protrusion on said upper and lower portions for engaging the adjacent vertebrae.

77. The method of claim 76, wherein said protrusion is at least a portion of a thread.

78. The method of claim 67, wherein the anchoring step includes the substep of anchoring said tubular member having projections projecting distally from said distal end for penetrably engaging the posterior surface of each of the adjacent vertebrae.

79. The method of claim 78, wherein said projections extend at least in part into the disc space.

80. The method of claim 78, wherein the anchoring step includes the substep of anchoring said tubular member further comprising a wall surrounding said passage, said projections being coextensive with said wall.

81. The method of claim 78, wherein the anchoring step includes the substep of anchoring said tubular member having at least two projections extending distally from said distal end of said tubular member, said distal end adapted to contact each of the vertebrae adjacent the disc space to be fused, said at least two projections adapted to penetrate the disc space so as to be located at least in part between the endplates of the vertebrae.

82. The method of claim 81, wherein said projections are at least in part co-linear with an outer perimeter of said tubular member.

83. The method of claim 82, wherein said projections are teeth.

84. The method of claim 81, wherein said projections are teeth being at least in part co-linear with an outer perimeter of said tubular member.

85. The method of claim 67, wherein the anchoring step includes the substep of anchoring said tubular member having a length defined by a distal portion and a proximal portion forming said length, said tubular member having a substantially uniform cross section along its distal portion.

86. The method of claim 67, wherein the anchoring step includes the substep of anchoring said tubular member having a substantially uniform cross section along its length.

87. The method of claim 86, wherein said distal end of said tubular member has a cross sectional configuration substantially the same as said substantially uniform cross-section of said tubular member.

88. The method of claim 67, wherein the anchoring step includes the substep of anchoring said tubular member having a distal end having a circumference that is uninterrupted and constant.

89. The method of claim 88, further comprising projections extending from said uninterrupted and constant circumference of said distal end of said tubular member for engaging the spine.

90. The method of claim 89, wherein said projections penetrate the disc space.

91. The method of claim 67, wherein the anchoring step includes the substep of anchoring said tubular member

having a width measured perpendicular to its height, the width of said tubular member when appropriately selected being less than one half of the width of the disc space.

92. The method of claim 67, further comprising the step of tapping the opening through said hollow tubular member.

93. The method of claim 67, wherein the providing step includes the substep of providing said implant having at least one of an insertion end and a trailing end, said trailing end being adapted to cooperatively engage a driver for inserting said implant through said hollow tubular member and into the opening.

94. The method of claim 66, wherein the method is performed without removing said tubular member between the anchoring step and the screwing step.

95. A method for preparing two adjacent vertebrae and a disc space therebetween to receive at least one implant, the method comprising the steps of:

providing an implant of a material suitable for human implantation;

positioning one end of a tubular member in contact with the adjacent vertebrae;

forming, through said tubular member, an opening across the disc space and into a portion of each of the two adjacent vertebrae; and

inserting said implant through said tubular member and into the opening.

96. The method of claim 95, wherein the positioning step includes the substep of positioning said guard having at least two projections extending distally from a distal end of said guard, said distal end adapted to contact each of the vertebrae adjacent the disc space to be fused, said at least two projections adapted to penetrate the disc space so as to be located at least in part between the endplates of said vertebrae.

97. The method of claim 95, wherein the positioning step includes the step of positioning one end of a guard in contact with the adjacent vertebrae of the posterior lumbar spine, said guard for providing protected access to the spinal disc and the adjacent vertebrae to prepare across the spinal disc and into the adjacent vertebrae the implantation space and to insert into the implantation space said spinal implant through said guard, said guard having a passage through which said spinal implant passes into the implantation space in the spine, said guard having a distal end configured to be placed against the adjacent vertebrae, said distal end having a first portion adapted to be placed in contact with one of the adjacent vertebrae and a second portion adapted to be placed in contact with the other of the adjacent vertebrae, said first and second portions having a fixed height therebetween.

98. The method of claim 95, wherein the method is performed without distracting the adjacent vertebrae between the forming step and the inserting step.

99. The method of claim 95, wherein the method is performed without removing said tubular member between the positioning step and the inserting step.

\* \* \* \* \*

UNITED STATES PATENT AND TRADEMARK OFFICE  
**CERTIFICATE OF CORRECTION**

PATENT NO. : 6,224,595 B1  
DATED : May 1, 2001  
INVENTOR(S) : Gary Karlin Michelson

Page 1 of 1

It is certified that error appears in the above-identified patent and that said Letters Patent is hereby corrected as shown below:

Title page.

Item [22], insert item [63] under the heading -- **Related Applications** -- as follows:  
-- Continuation of Application Ser. No. 07/968,240, filed Oct. 29, 1992, now issued as Patent No. 5,741,253, which is a continuation of Application Ser. No. 07/698,674 filed May 10, 1991, abandoned, which is a divisional of Application Ser. No. 07/205,935, filed Jun. 13, 1988, now Patent No. 5,015,247. --

Column 1.

Insert before line 1 -- This application is a continuation of application Serial No. 07/968,240, filed October 29, 1992, now issued, which is a continuation of application Serial No. 07/698,674, filed May 10, 1991, abandoned, which is a divisional of application Serial No. 07/205,935, filed June 13, 1988, now U.S. Patent No. 5,015,247, all of which are incorporated herein by reference. --

Column 15, claim 63.

Line 1, change "62" to -- 61 --; and

Column 16, claim 73.

Line 1, change "72" to -- 69 --.

Signed and Sealed this

Twenty-fifth Day of December, 2001

Attest:



Attesting Officer

JAMES E. ROGAN  
Director of the United States Patent and Trademark Office