



US006120502A

United States Patent [19]

[11] Patent Number: **6,120,502**

Michelson

[45] Date of Patent: **Sep. 19, 2000**

[54] **APPARATUS AND METHOD FOR THE DELIVERY OF ELECTRICAL CURRENT FOR INTERBODY SPINAL ARTHRODESIS**

0 599 419 A2	6/1994	European Pat. Off. .
0 179 695	4/1986	France .
2 581 336	11/1986	France .
1961531	7/1970	Germany .
2446039	9/1974	Germany .
3101333 A1	12/1981	Germany .
3132520 A1	6/1982	Germany .
3505567 A1	6/1985	Germany .
4104359 A1	2/1991	Germany .
106 101	7/1939	Sweden .
WO84/01289	4/1984	WIPO .

[76] Inventor: **Gary Karlin Michelson**, 438 Sherman Canal, Venice, Calif. 90291

[21] Appl. No.: **08/250,177**

[22] Filed: **May 27, 1994**

Related U.S. Application Data

[63] Continuation-in-part of application No. 08/052,211, Apr. 22, 1993, abandoned, which is a continuation of application No. 07/546,849, Jul. 2, 1990, abandoned, which is a continuation of application No. 07/212,480, Jun. 28, 1988, abandoned, which is a continuation-in-part of application No. 07/968,240, Oct. 29, 1992, which is a continuation of application No. 07/698,674, May 10, 1991, abandoned, which is a division of application No. 07/205,935, Jun. 13, 1988, Pat. No. 5,015,247.

[51] **Int. Cl.⁷** **A61B 17/56**
 [52] **U.S. Cl.** **606/61; 623/17; 607/51**
 [58] **Field of Search** **606/61, 62, 69-77; 623/17; 600/9, 13, 15; 607/50, 51, 52**

References Cited

U.S. PATENT DOCUMENTS

Re. 31,865	4/1985	Roux .
Re. 34,871	3/1995	McGuire et al. .
D. 245,259	8/1977	Shen .
D. 257,511	11/1980	Zahn .
350,420	10/1886	Dillon .
1,137,585	4/1915	Craig .
2,065,659	12/1936	Cullen .
2,181,746	11/1939	Siebrandt .
2,243,718	5/1941	Moreira .

(List continued on next page.)

FOREIGN PATENT DOCUMENTS

0162005	4/1985	European Pat. Off. .
0 260 044	3/1988	European Pat. Off. .
0 303 241	2/1989	European Pat. Off. .
0 307 241	3/1989	European Pat. Off. .
0499465 A1	8/1992	European Pat. Off. .

OTHER PUBLICATIONS

"The SpF-T Spinal Fusion Stimulator: An Efficacious Adjunct that Meet the Diverse Needs of Spine Patients", EBI Medical Systems, Aug., 1991.

"The Use of Direct Current For Electrically Induced Osteogeneses, The Positive Effect of An Electronegative Charge on Bone Growth", EBI Medical Systems, Feb., 1993.

"Direct Current Electrical Bone Growth Stimulation For Spinal Fusion", Kane, W.J., Spine, vol. 13, No. 3, Mar. 1988. EBI Med. Systems, the Use of Direct Current for Electrically Induced Osteogenesis 1993.

EBI Medical Systems, The SpF-T Spinal Fusion Stimulator: An Efficacious Adjunct that Meets the Diverse Needs of Spine Patients, (1991).

Primary Examiner—Michael A. Brown
Attorney, Agent, or Firm—Martin & Ferraro LLP

[57] ABSTRACT

An electrical bone growth promotion apparatus and method for the delivery of electrical current to an implant surgically implanted within the intervertebral space between two adjacent vertebrae of the spine to promote bone growth and the fusion process to areas adjacent to the implant. The apparatus of the present invention comprises a self contained implant having a surgically implantable, renewable power supply and related control circuitry for delivering electrical current directly to the implant and thus directly to the area in which the promotion of bone growth is desired. The desired areas of bone growth promotion may be controlled by conducting negative charge only to the desired location of bone growth promotion.

128 Claims, 7 Drawing Sheets

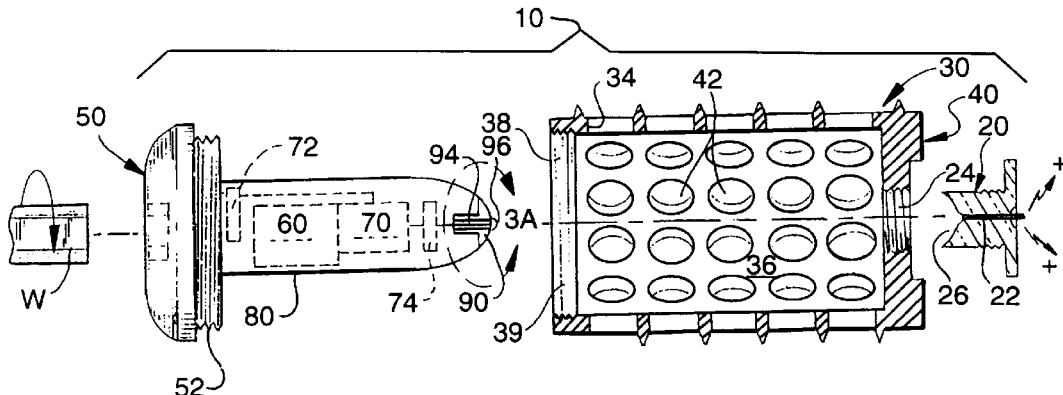

U.S. PATENT DOCUMENTS					
			4,535,485	8/1985	Ashman et al. .
			4,542,539	9/1985	Rowe, Jr. et al. .
			4,545,374	10/1985	Jacobson .
			4,547,390	10/1985	Ashman et al. .
			4,549,547	10/1985	Brighton et al. .
			4,552,200	11/1985	Sinha et al. .
			4,553,273	11/1985	Wu .
			4,554,914	11/1985	Kapp et al. .
			4,570,623	2/1986	Ellison et al. .
			4,570,624	2/1986	Wu .
			4,599,086	7/1986	Doty .
			4,600,000	7/1986	Edwards .
			4,602,638	7/1986	Adams 607/60
			4,604,995	8/1986	Stephens .
			4,608,052	8/1986	Van Kampen et al. .
			4,611,581	9/1986	Steffee .
			4,619,264	10/1986	Signh 607/52
			4,628,921	12/1986	Rouso .
			4,634,720	1/1987	Dorman et al. .
			4,636,217	1/1987	Ogilvie et al. .
			4,636,526	1/1987	Dorman et al. .
			4,645,503	2/1987	Lin et al. .
			4,653,486	3/1987	Coker .
			4,655,777	4/1987	Dunn .
			4,661,536	4/1987	Dorman et al. .
			4,677,883	7/1987	Lee .
			4,677,972	7/1987	Tornier .
			4,693,721	9/1987	Ducheyne .
			4,696,290	9/1987	Steffee .
			4,698,375	10/1987	Dorman et al. .
			4,710,075	12/1987	Davison .
			4,713,004	12/1987	Linkow et al. .
			4,714,469	12/1987	Kenna .
			4,721,103	1/1988	Freedland .
			4,736,738	4/1988	Lipovsek et al. .
			4,743,256	5/1988	Brantigan 623/17
			4,743,260	5/1988	Burton .
			4,759,766	7/1988	Buettner-Janz et al. .
			4,759,769	7/1988	Hadman et al. .
			4,769,881	9/1988	Pedigo et al. .
			4,781,591	11/1988	Allen .
			4,790,303	12/1988	Steffee .
			4,820,305	4/1989	Harms et al. .
			4,830,000	5/1989	Shutt .
			4,834,757	5/1989	Brantigan .
			4,848,327	7/1989	Perdue .
			4,851,008	7/1989	Johnson .
			4,863,477	9/1989	Monson .
			4,865,603	9/1989	Noiles .
			4,877,020	10/1989	Vich .
			4,878,915	11/1989	Brantigan .
			4,903,882	2/1990	Long .
			4,904,260	2/1990	Ray et al. .
			4,904,261	2/1990	Dove et al. .
			4,911,718	3/1990	Lee et al. .
			4,913,144	4/1990	Del Medico .
			4,936,848	6/1990	Babgy .
			4,943,291	7/1990	Tanguy .
			4,955,885	9/1990	Meyers .
			4,955,908	9/1990	Frey et al. .
			4,957,495	9/1990	Kluger .
			4,960,420	10/1990	Goble et al. .
			4,961,740	10/1990	Ray 623/16
			4,968,316	11/1990	Hergenroeder .
			4,969,888	11/1990	Scholten et al. .
			4,987,904	1/1991	Wilson .
			5,015,247	5/1991	Michelson 606/72
			5,015,255	5/1991	Kuslich .
			5,026,373	6/1991	Ray et al. .
			5,030,236	7/1991	Dean .
			5,055,104	10/1991	Ray .
			5,059,193	10/1991	Kuslich .

5,071,437	12/1991	Steffee .	5,393,036	2/1995	Sheridan .
5,084,050	1/1992	Draenert .	5,396,880	3/1995	Kagan et al. .
5,102,414	4/1992	Kirsch .	5,397,364	3/1995	Kozak et al. .
5,122,130	6/1992	Keller .	5,425,772	6/1995	Brantigan .
5,123,926	6/1992	Pisharodi .	5,435,723	7/1995	O'Brien .
5,192,327	3/1993	Brantigan .	5,441,527	8/1995	Erickson 607/51
5,258,031	11/1993	Salib et al. .	5,489,307	2/1996	Kuslich et al. .
5,263,953	11/1993	Bagby .	5,489,308	2/1996	Kuslich et al. .
5,292,252	3/1994	Nickerson et al. .	5,571,109	11/1996	Bertagnoli .
5,306,309	4/1994	Wagner et al. .	5,807,397	9/1998	Barreras .
5,364,399	11/1994	Lowery et al. .	B1 4,232,679	5/1988	Schulman .
5,370,662	12/1994	Stone et al. .			

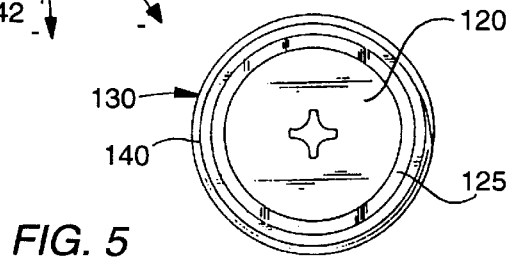
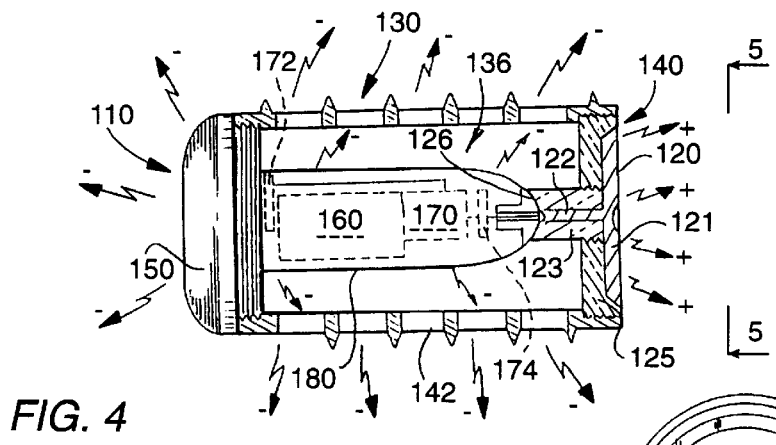
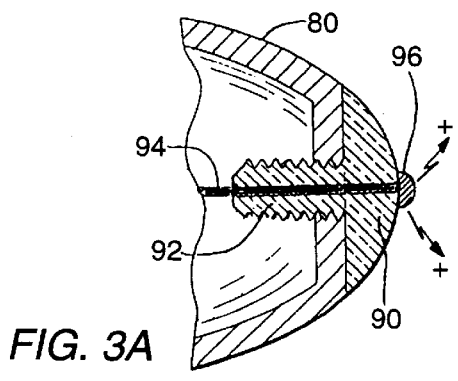
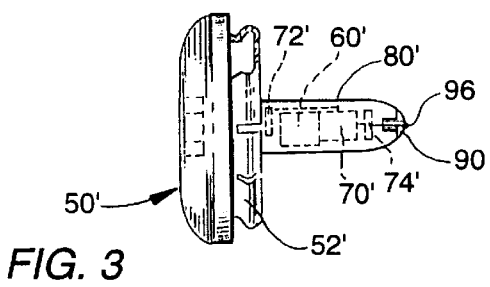
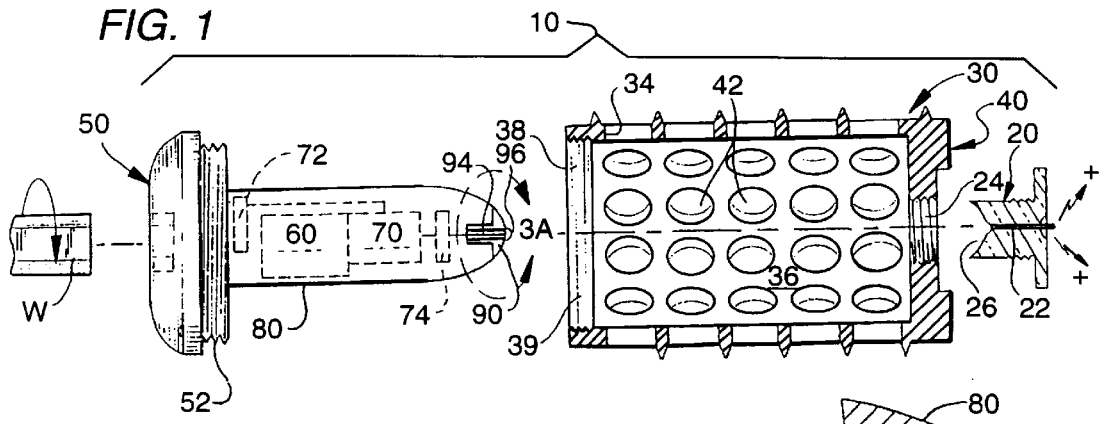

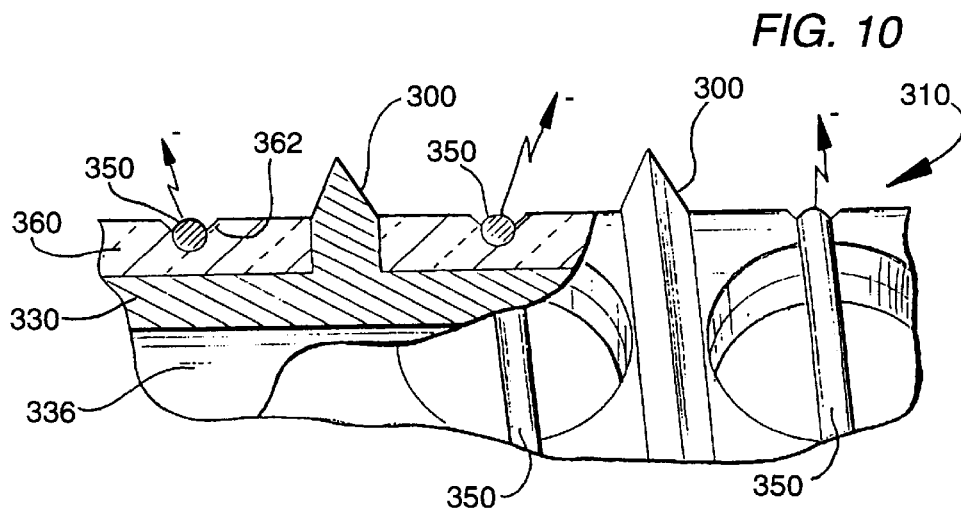
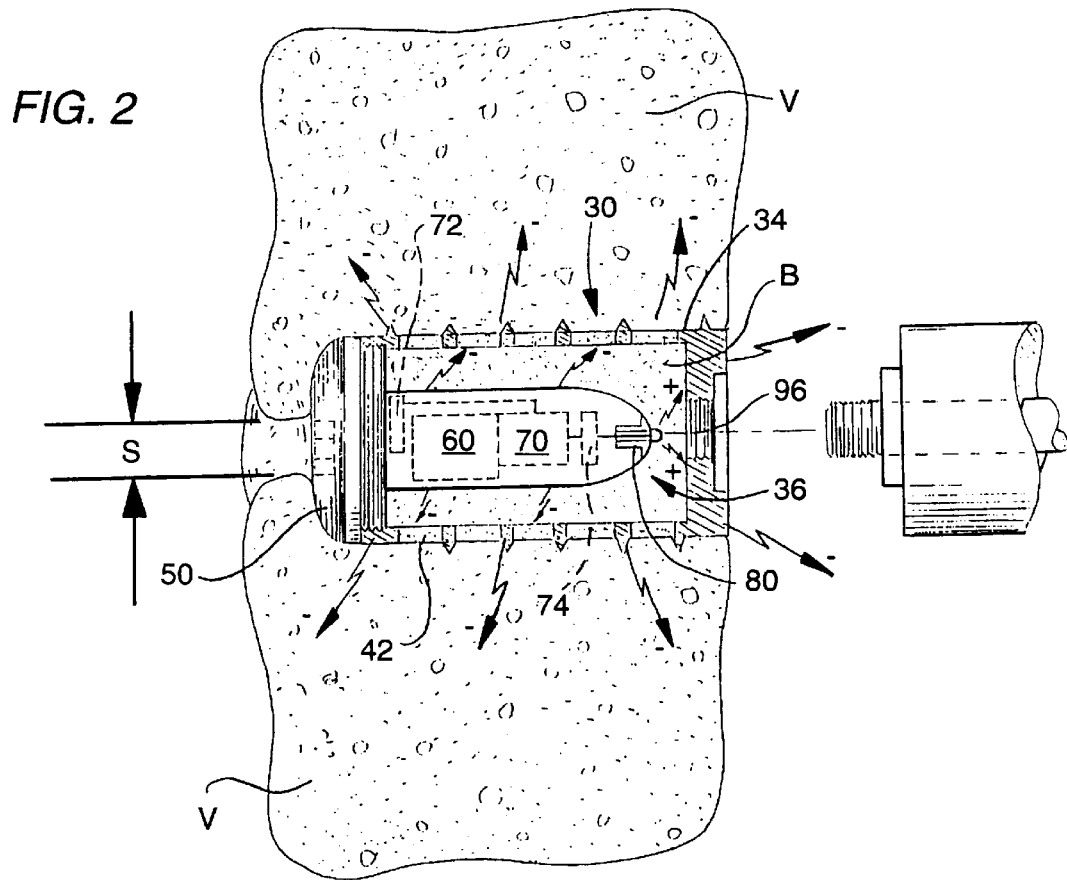

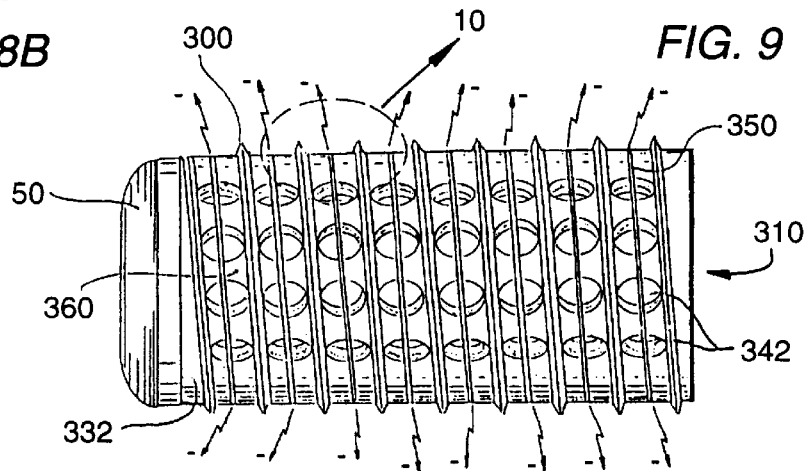
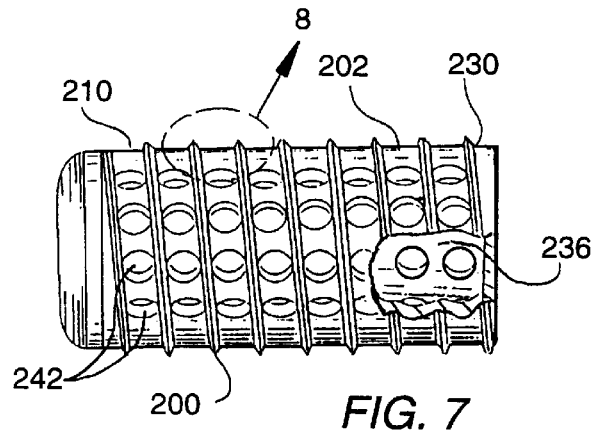
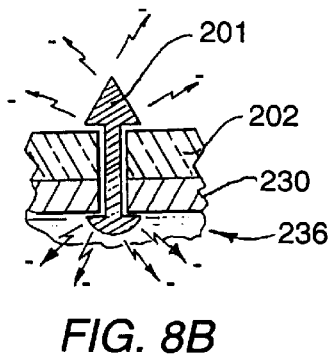
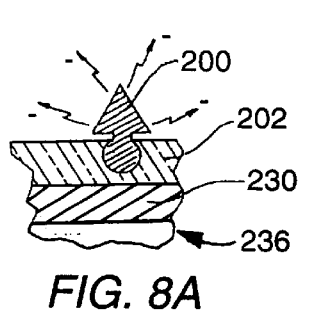
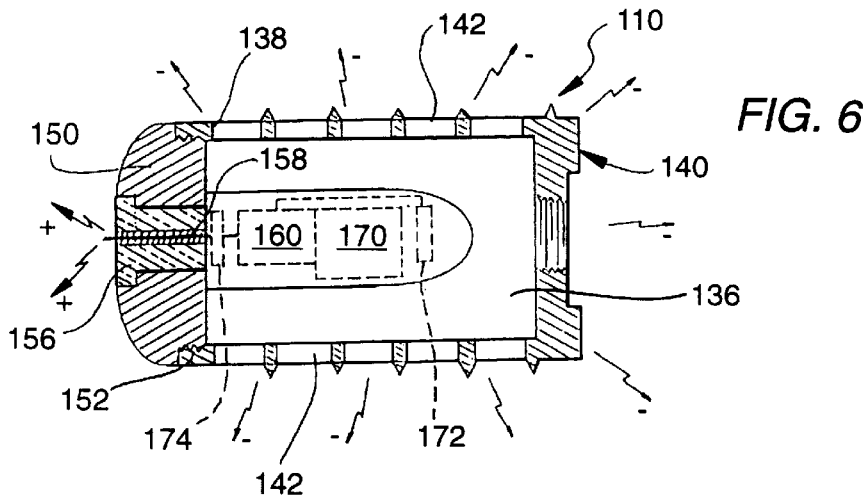

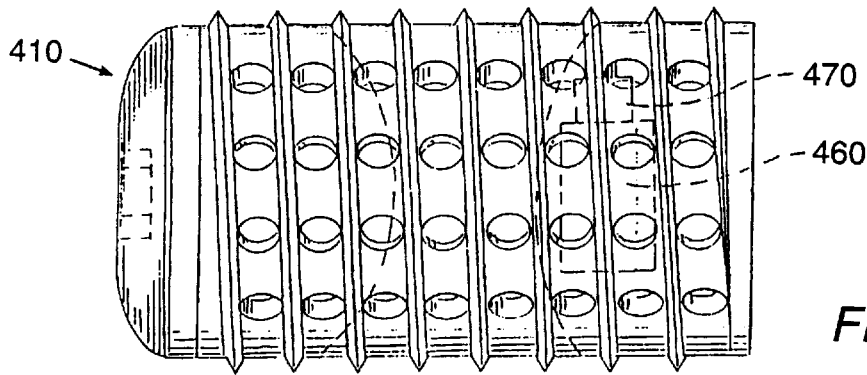
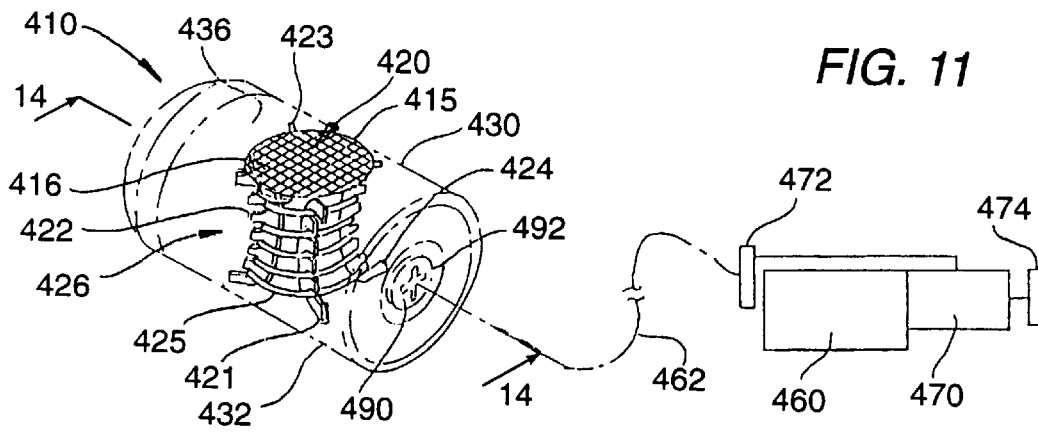

FIG. 15

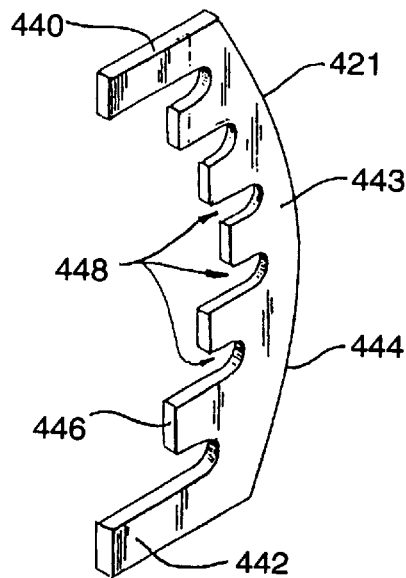

FIG. 13

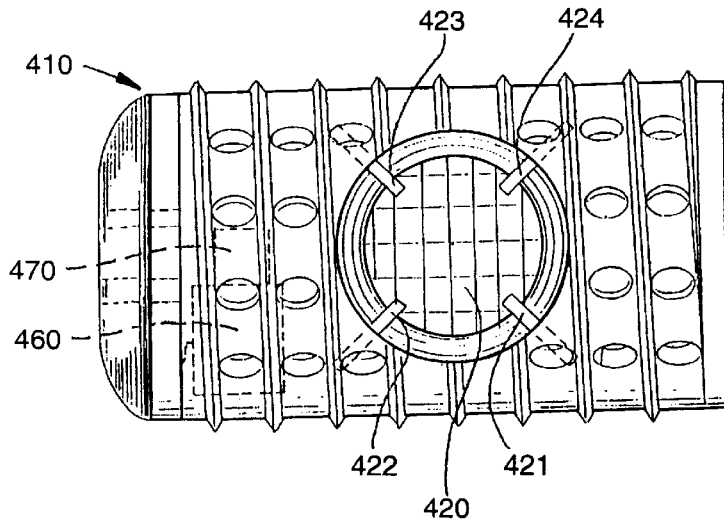

FIG. 14

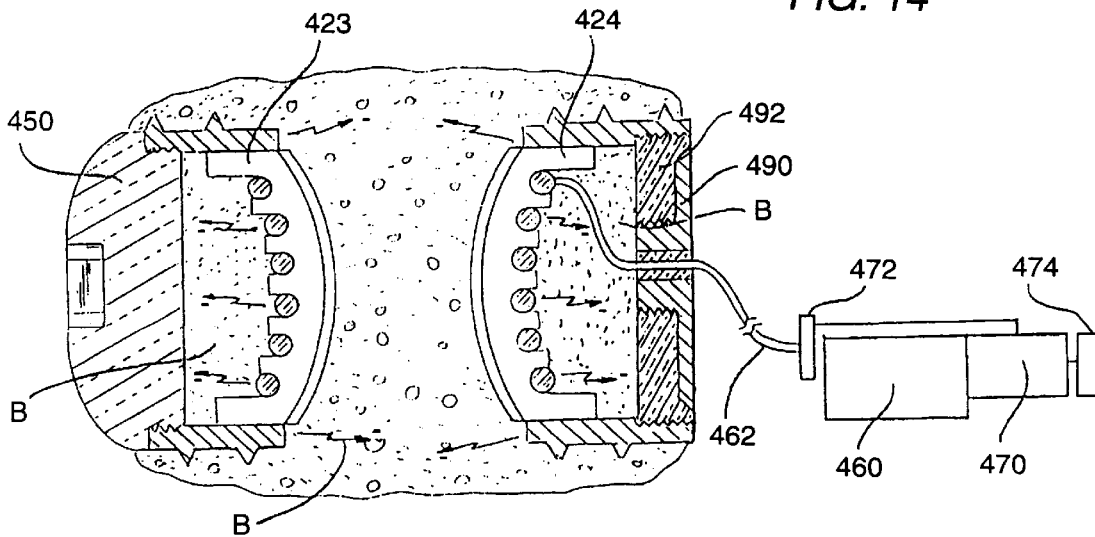

FIG. 16

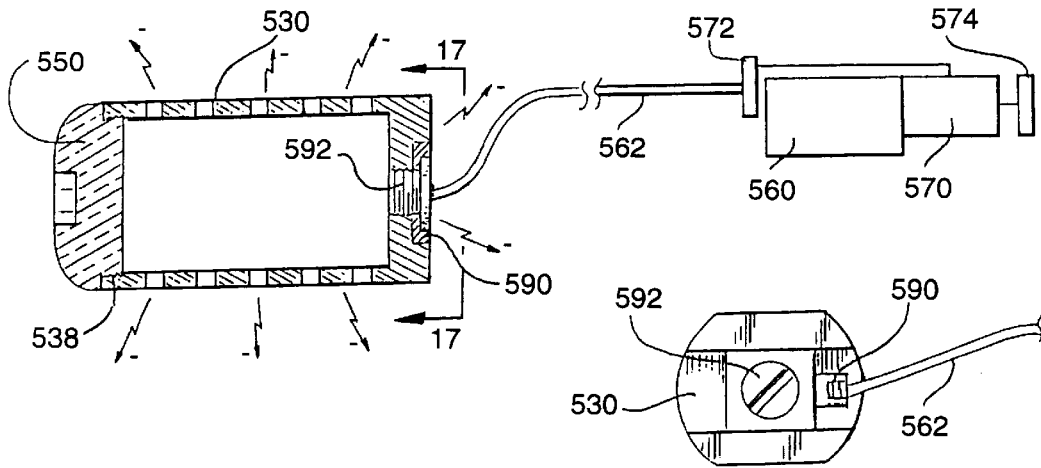

FIG. 17

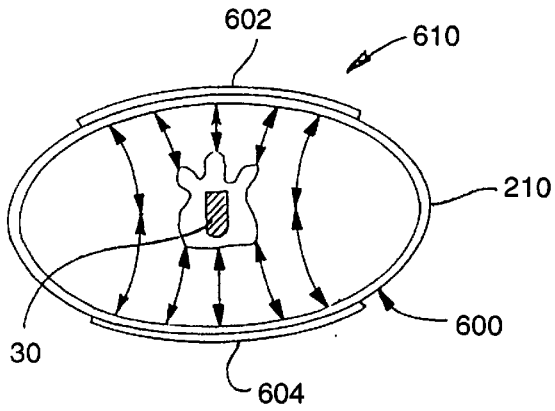
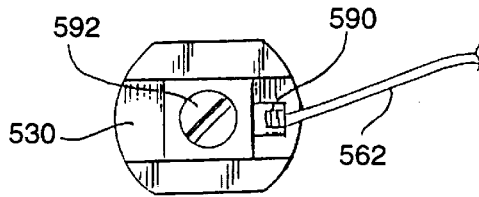

FIG. 19

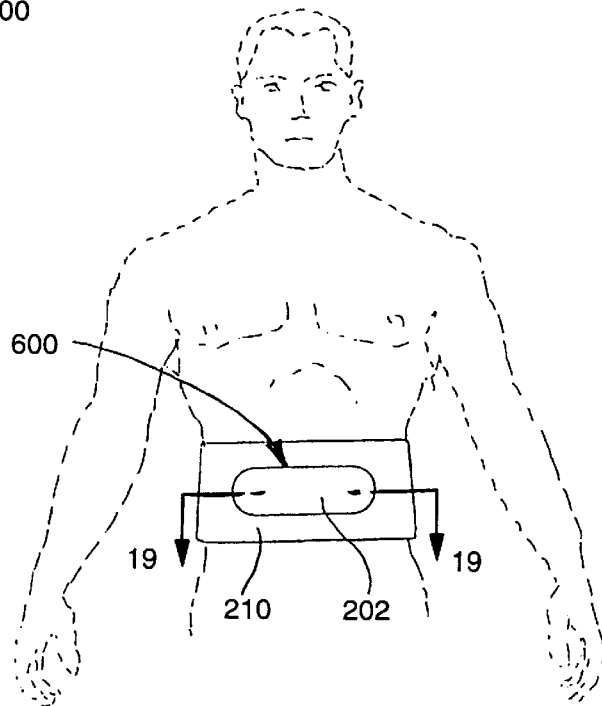
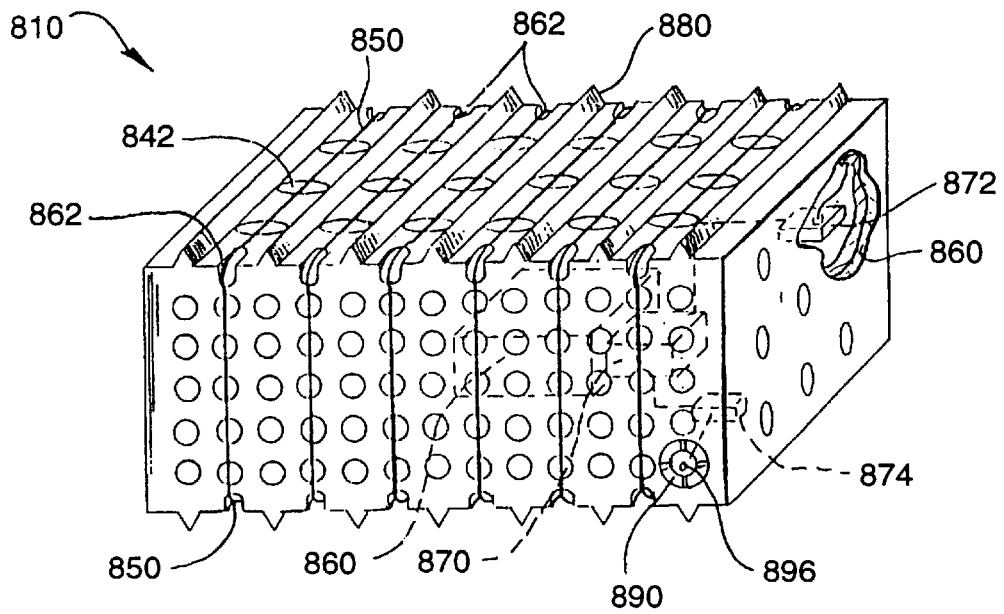
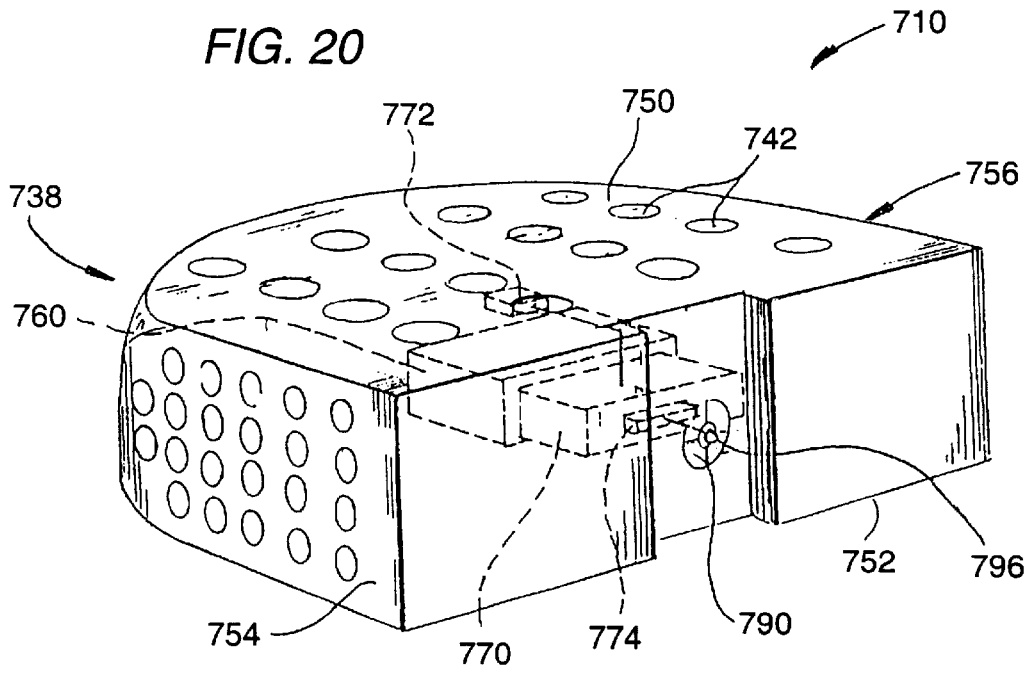

FIG. 18



APPARATUS AND METHOD FOR THE DELIVERY OF ELECTRICAL CURRENT FOR INTERBODY SPINAL ARTHRODESIS

RELATED APPLICATIONS

This application is a continuation in part of application Ser. No. 08/052,211 filed on Apr. 22, 1993, now abandoned, which is a continuation of application Ser. No. 07/546,849 filed on Jul. 2, 1990, now abandoned, which is a continuation of application Ser. No. 07/212,480, filed on Jun. 28, 1988, which has now been abandoned.

This application is also a continuation in part of application Ser. No. 07/968,240 filed on Oct. 29, 1992 which is a continuation of application Ser. No. 07/698,674 filed on May 10, 1991, now abandoned, which is a divisional application of application Ser. No. 07/205,935 filed on Jun. 13, 1988 and issued as U.S. Pat. No. 5,015,247 on May 14, 1991.

BACKGROUND OF THE INVENTION

1. Field of the Invention

This invention relates to interbody bone fusion devices, and more particularly to an apparatus and method for the delivery of electrical current to a spinal fusion implant and to interbody fusion material for inducing bone growth and aiding in spinal arthrodesis.

2. Description of the Related Art

The spine may be fused along any of its various surfaces, or internally within the interspaces of the vertebrae. Various interbody fusion devices have been developed to promote interbody fusions of the spine, such as that of Michelson, U.S. Pat. No. 5,015,247, issued on May 14, 1991, Brantigan U.S. Pat. No. 4,743,256, issued on May 10, 1988, and others. Such devices have helped to achieve spinal fusion by providing structural support, presenting bone promoting substances to the fusion site, increasing the surface area available to participate in the fusion, and by being both self-stabilizing and stabilizing to a spinal segment.

During normal bone repair, the area around the fracture of the bone exhibits negative charge. The application of electrical current to negatively charge a site in which spinal fusion is desired simulates the bone's own normal repair process and promotes osteogenesis. The application of electrical current to negatively charge a site in which osteogenesis is desired, creates an electrochemical reaction ($4e^- + O_2 + 2H_2O \rightarrow 4OH^-$) which lowers the oxygen tension (decreasing the O_2) to stimulate osteoblastic activity and promotes bone formation. Further, the formation of the hydroxyl radical (OH^-) raises the local tissue pH which of itself is favorable to bone production and further promotes increases in the presence of alkaline phosphatase, a very potent stimulant of bone formation in its own right. Still further, there appears to be a direct effect of electrical current to present a negative charge at the cellular level so as to upset the resting electrical potential of the cell membrane with a resultant electrical perturbation within the cell, the net effect of which is promotional to the cellular activity of bone formation. Finally, the electromagnetic field generated by the passage of electrical current appears to be independent of that current (on the basis of magnetism alone) to be promotional of bone growth, though the mechanism remains unknown.

Conversely, the application of electrical current to positively charge an area of bone inhibits osteogenesis and thus inhibits bone formation. Therefore, the application of elec-

trical current to deliver positive charge to an area of bone may be used to control the bone fusion process so that it does not occur in undesired areas such as within the spinal canal.

The bone fusion process is a race against time, for eventually, the body will give up its attempt to complete that process. Well-known within the field of surgery is the use of electrical current delivered internally, or applied externally relative to a patient's body to promote bone growth and thus promote the bone healing or fusion process. However in regard to the spine, none of the interbody fusion devices of the past incorporate the use of electric current to stimulate bone growth, to increase the rate of osteogenesis and the spinal fusion process.

To date the use of electric current to promote bone growth in the spinal fusion process has taken two forms. The first is the use of an internally implanted electrical pulse generator, with a cathode wire leading from the pulse generator being wrapped about a bone plug harvested from the patient's body which is then inserted into the intervertebral space. These devices however have been continually plagued with problems that include breakage of the lead wires from the generator to the fusion site and a second surgery to remove the generator implanted in the patient's body at a remote location to the fusion site after the service life of the battery has expired. The power supplies of these implantable generators have been ineffective due to their limited service life, which may be shorter than the time needed to attain solid fusion, and problematic due to the potential for tissue damage in the event of a leak. The latter concern prompts most physicians to perform a second surgical procedure to explant the generator and internal battery supply. The additional surgery to explant the device increases the risk of infection and danger to the patient, and results in unnecessary additional costs.

The second form in which electric current has been used in the past to stimulate spinal fusion required the wearing, external to the body of the patient, of an electromagnetic coil or coils. Unfortunately, neither of these methods when utilized in conjunction with the known methods of interbody arthrodesis has proven fully effective.

Therefore, a need exists for the means and method of improving upon and/or perfecting the conjoined use of an improved interbody fusion device other than bone alone, and the promotion of bone growth with electrical current.

SUMMARY OF THE INVENTION

The present invention is directed generally to an apparatus and method for the delivery of electrical current to a surgically implanted device in a location in which bone growth is desired. More specifically, the present invention discloses an electrical bone growth promotion (EBGP) spinal fusion implant positioned within the intervertebral space between two adjacent vertebrae of the spine to promote and induce bone growth in the spinal fusion process. The EBGP implant of the present invention comprises a power supply and related control circuitry for delivering electrical current directly to the housing of the EBGP implant which is surgically implanted within the intervertebral space between two adjacent vertebrae. The housing of the EBGP implant of the present invention is at least in part electrically conductive such that at least a portion thereof serves as an active cathode to deliver negative charge directly to the spinal fusion site and to any bone material contained within the EBGP implant and thus directly to the area in which the promotion of bone growth is most desired. As positive charges do not promote bone growth, but actually induce

resorption of bone, the areas of bone growth promotion may be controlled either by conducting only negative charges to the location for bone growth promotion is desired or by conducting negative charges to the area in which bone growth promotion is desired and at the same time conducting positive charges to any area in which bone growth is to be inhibited. Thus, the housing or a portion thereof, serves as an active cathode for delivering negative charge or a combination active cathode and active anode for delivering negative charge and for delivering positive charge, respectively, to bone mass.

As an electrical bone growth promotion apparatus, the EBGp implant of the present invention is not limited in its use with any particular spinal fusion implant. Many different embodiments of the EBGp implant of the present invention are possible. For example, in a first embodiment of the EBGp implant, an implantable power supply and related control circuitry are completely contained within a hollow central chamber of the housing of the EBGp implant such that the EBGp implant is a self-contained unit positioned within the intervertebral space between two adjacent vertebrae of the spine and may deliver electrical charge directly to the fusion site to promote spinal arthrodesis. The power supply and control circuitry may be contained in an extending portion of a cap used to close one end of the hollow central chamber of the housing and thus may be inserted into the EBGp implant which itself may in the remainder be filed with bone.

The EBGp implant of the present invention is a self-contained unit which overcomes the problems described above associated with the prior art devices for delivering electrical current to promote bone fusion. The EBGp implant of the present invention conducts electrical current via its housing, or a portion thereof, to an area of bone adjacent to the EBGp implant in which the promotion of bone growth is desired. As no lead wires are present, the problem of breakage of such wires experienced by the devices of the past has been overcome. Further, as the power supply and related control circuitry are fully contained within the EBGp implant of the present invention there is no need to implant a power supply and/or said related control circuitry at a remote location from the EBGp implant. Further still, as the power supply and related control circuitry become entombed in the bone mass upon completion of the bone fusion process, no additional surgery is required to explant the power supply and/or control circuitry as was the case with the prior art. Thus, as no explantation is required, the possibility of infection to the patient and other risks inherent to all surgical procedures are eliminated, while also substantially reducing the costs of utilizing electric current to promote bone growth in the bone fusion process.

In a first variation of the first embodiment, the external housing of the EBGp implant, the threaded portion, or any part of the housing of the EBGp implant, may be utilized as an active cathode by coupling the cathode lead from the power supply and/or control circuitry contained within the EBGp implant to the housing or a portion thereof. For example, the housing may be a spinal fusion implant such as that described by Michelson in U.S. Pat. No. 5,015,247, issued on May 14, 1991, and could utilize its continuous external thread much like a wound coil with the threaded portions being separated from one another and from the remainder of the spinal implant by an electrically non-conductive ceramic material, and further that non-conductive material itself may also be osteoinductive.

In a second variation of the first embodiment, the housing of the EBGp implant further includes an opening through

which bone growth from one vertebra to a second adjacent vertebra may occur. Coaxial with the opening is a coil that is coupled to the cathode lead of the power supply. The coil acts as an active cathode to deliver a negative charge and promote bone growth through the opening and coil. In a further modification of this variation the cathode continues as a coil about the housing of the EBGp.

In a second embodiment of the EBGp implant of the present invention, any of a number of already known or conventional surgically implantable power supply units and related control circuitry may be placed within the body of the patient at a location remote to the spine. A lead wire couples the power supply and/or control circuitry to the housing of the EBGp implant, such as a spinal fusion implant, situated within the intervertebral space between and in contact with two adjacent vertebrae. The EBGp implant which is at least in part not made of bone, and that part also being electrically conductive, is used to conduct electrical current to the interbody spinal fusion mass. In one variation of the second embodiment, the entire housing of the EBGp implant is electrically conductive and functions as an active cathode to deliver negative charge to the area of bone adjacent thereto. In a second variation of the second embodiment, the housing of the EBGp implant may be made of a combination of electrically conductive and non-conductive materials such that a first portion of the housing of the EBGp implant is an active cathode specifically utilized for the delivery of the negative electrical charge as discussed above for the first variation of the first embodiment and a second portion of the housing is an active anode specifically utilized to deliver positive charge to the area in which bone growth is not desired. The area of the anode may be minimized to reduce the area in which bone growth is inhibited or may be larger such that the anode is used to prevent bone formation over a substantial area.

In order to make efficient use of the power supply, rather than conducting electrical current to the entire housing of the EBGp implant of the present invention which would require a large power supply, electrical current may be conducted only to the threads of the housing or to a wire coil insulated from the remainder of the housing. In this manner less current is drained from the power supply without reducing the effectiveness of the electrical charge delivered to the site in which bone fusion is desired since the electrical field created about the coil or threads extends beyond the coil of the threads.

In a third embodiment of the EBGp implant of the present invention, a spinal fusion implant is preferably implanted surgically within the intervertebral space between two adjacent vertebrae and is wholly or partially ferromagnetic. The spinal fusion implant is hermetically sealed in a jacket composed of a non-ferromagnetic, biocompatible material which may or may not be electrically conductive. An electromagnetic field is produced by an electromagnetic coil or coils worn external to the patient's body. The spinal fusion implant may be inductively coupled to the electromagnetic fields generated and transmitted by the external coils, and thereby generate its own electromagnetic field and accompanying electrical currents. These internal fields and currents are localized within that segment of the spine in which the spinal fusion implant is located, and will induce bone growth and promote the spinal fusion process.

In a first variation of the third embodiment, the EBGp implant is wholly or partially powered by electrical currents induced within the EBGp implant by the externally-applied electromagnetic fields. Likewise, any battery source integrated into the EBGp implant may be recharged via such

electromagnetic induction to renew the service life of the battery source and thus extend the period of time in which bone growth may be electrically promoted. The EBG implant in this embodiment delivers electrical current and replenishes the power supply when inductively coupled to externally applied electromagnetic fields.

In another embodiment of the EBG implant of the present invention, the power supply is surgically implanted within the body of the patient but at a location remote to the spine such as a subcutaneous implantation, and is rechargeable in response to the application of external magnetic fields.

In still another embodiment of the EBG implant of the present invention, the battery source is charged by an external power source by ferromagnetic induction and continues to deliver charges via that battery source even after the activity of the external coil ceases.

OBJECTS OF THE PRESENT INVENTION

It is an object of the present invention to provide an electrical bone growth promotion implant in which a power supply, related control circuitry, and delivery system are entirely self-contained within a spinal fusion implant, thus eliminating the need to violate other body tissues to situate the implant, thereby limiting the extent of surgery, the time for surgery, the blood loss, and the risk of infection;

It is another object of the present invention to provide an electrical bone growth promotion implant for delivering electrical current to promote bone growth in a biomechanically and biophysiological optimal place so as to induce spinal fusion within the compressive weight bearing axis of the spine;

It is yet another object of the present invention to provide an electrical bone growth promotion implant that eliminates the need for lead wires, the breakage of which has historically been a major source of failure in regard to the use of electrostimulators in general;

It is a further object of the present invention to provide an electrical bone growth promotion implant in which with successful arthrodesis, the encapsulated power supply and/or related control circuitry becomes permanently entombed in the bone fusion mass thus eliminating the need to perform a second surgical procedure for its removal;

It is still a further object of the present invention to provide an electrical bone growth promotion implant in which an active cathode is fully contained within the bone fusion mass;

It is another object of the present invention to provide an electrical bone growth promotion implant in which the power supply and/or related control circuitry combined is an internal extension of either a spinal fusion implant itself or of an insertable cap of the spinal fusion implant;

It is a further object of the present invention to provide an electrical bone growth promotion implant which will receive externally applied electromagnetic fields and thereby generate electromagnetic fields and electric currents affecting the bone within and adjacent to the space between two adjacent vertebrae; and

It is yet a further object of the present invention to provide an electrical bone growth promotion implant in which the power source for delivering electric current to the implant is wholly or partially supplied or recharged by externally applied electromagnetic fields.

These and other objects of the present invention will become apparent from a review of the accompanying drawings and the detailed description of the drawings.

BRIEF DESCRIPTION OF THE DRAWINGS

FIG. 1 is an exploded elevational side view, partially in cross section, of the electrical bone growth promotion implant of the present invention.

FIG. 2 is an elevational side view, partially in cross section, of the electrical bone growth promotion implant of the present invention inserted between two adjacent vertebrae of the spine.

FIG. 3 is an alternative embodiment of the cap used for closing the open end of the electrical bone growth promotion implant of the present invention.

FIG. 3A is an enlarged fragmentary view along line 3A of FIG. 1 showing in cross section the end of the casing.

FIG. 4 is a side elevational view, partially in cross section, of a first alternative embodiment of the electrical bone growth promotion implant of the present invention having one end in which a portion thereof is made of a non-conductive material and insulated from the rest of the implant such that different polarities of electrical charges may be delivered to different parts of the implant as illustrated by the electrical field arrows.

FIG. 5 is an end view of the electrical bone growth promotion implant of the present invention along line 5—5 of FIG. 4.

FIG. 6 is a cross sectional, side elevational view of a second alternative embodiment of the electrical bone growth promotion implant of the present invention having a cap at one end in which a portion thereof is made of non-electrically conductive material.

FIG. 7 is a side elevational view of a third alternative embodiment of the electrical bone growth promotion implant of the present invention having outer threaded portions that are separated from the rest of the implant by a non-electrically conductive insulating material.

FIG. 8A is an enlarged fragmentary cross sectional view of the third alternative embodiment of the electrical bone growth promotion implant taken along line 8 of FIG. 7 showing the threaded portion being anchored to the non-electrically conductive material.

FIG. 8B is an enlarged fragmentary cross sectional view of the third alternative embodiment of the electrical bone growth promotion implant taken along line 8 of FIG. 7 showing the thread portion being anchored to and passing through a non-conductive material.

FIG. 9 is a side elevational view of a fourth alternative embodiment of the electrical bone growth promotion implant of the present invention having an external wire coil interposed between the external threads of the implant and insulated from the remainder of the implant by a non-electrically conductive insulating material.

FIG. 10 is an enlarged fragmentary view taken along line 10 of FIG. 9 showing the external wire coil being held in place between the external threads of the implant by a non-electrically conductive insulating material.

FIG. 11 is a perspective view of a fifth alternative embodiment of the electrical bone growth promotion implant of the present invention having an opening surrounded by a wire coil coaxial with the opening electrically connected to a remote power source.

FIG. 12 is a side view of a sixth alternative embodiment of the electrical bone growth promotion implant of the present invention having an opening surrounded by a wire coil coaxial with the opening and electrically coupled to an internal power source.

FIG. 13 is a top plan view of the electrical bone growth promotion implant of FIG. 12 showing the opening.

FIG. 14 is a cross sectional side elevation view along lines 14—14 of FIG. 11 of the bone growth promotion implant of the present invention having an external power source and illustrating the bone growth from one vertebra to a second adjacent vertebra that occurs during the spinal fusion process.

FIG. 15 is a perspective view of a structural support member used to support a wire coil coaxial with the vertical opening of the electric bone growth promotion implant of the present invention.

FIG. 16 is a cross sectional side elevational view of a seventh alternative embodiment of the electrical bone growth promotion implant of the present invention having an insulated cap at one end, a cathode lead from an external power supply connected to.

FIG. 17 is an end view of the seventh alternative embodiment of the electrical bone growth promotion implant along 17—17 of FIG. 16.

FIG. 18 is a front elevational view of an externally worn electromagnetic energy transmitter for transmitting an electromagnetic field to an implanted spinal fusion implant.

FIG. 19 is a cross sectional view taken along lines 19—19 of FIG. 18 illustrating the transmission of electromagnetic energy generated by the electromagnetic energy transmitter to a spinal fusion implant positioned within the patient's spine.

FIG. 20 is a perspective side view of an eighth alternative embodiment of the electric bone growth promotion implant of the present invention having an internal power supply and generator shown in hidden line.

FIG. 21 is a perspective view of a ninth alternative embodiment of the electric bone growth promotion implant of the present invention having an internal power supply and generator shown in hidden line.

DETAILED DESCRIPTION OF THE DRAWINGS

Referring to FIGS. 1 and 2, the electrical bone growth promotion (EBGP) implant of the present invention is shown and is generally referred to by the numeral 10. In the preferred embodiment, the EBGP implant 10 comprises a housing 30 as shown in FIG. 2 which is implanted in the intervertebral disc space S between adjacent vertebrae V₁ and V₂ in a segment of the spine for achieving arthrodesis.

As shown in FIG. 1, housing 30 includes a hollow tubular body that is at least partially cylindrical having side walls 34 and preferably made of a surgically implantable and electrically conductive material such as, but not limited to, titanium. The housing 30 has a hollow central chamber 36 that is open at its distal end 38, is closed at its proximal end 40 and has a series of macro-sized openings 42 perforating the side walls 34. The macro-sized openings 42 preferably have a diameter in the range of approximately 2.0 mm to approximately 6.0 mm to allow for the macro fixation of the adjacent vertebrae V₁ and V₂. During the fusion process, bone growth occurs from each of the two adjacent vertebrae V₁ and V₂ through the macro-sized openings 42 to any natural or artificial bone fusion enhancing material that may be contained within the central chamber 36 so as to form a single solid mass.

The housing 30 has a similar structure and configuration of a spinal implant such as, but not limited to, the spinal fusion implant taught by Michelson in U.S. Pat. No. 5,015,247. The housing 30 is preferably, at least in part, electrically

conductive and is made of material stronger than bone to provide structural support to the two adjacent vertebrae V₁ and V₂ while awaiting bone ingrowth, becoming firmly and permanently fixed in place once bone growth has occurred. To further enhance bone growth, the housing 30 may be coated with a bone growth inducing material such as, but not limited to, hydroxyapatite, hydroxyapatite tricalcium phosphate, bone morphogenic protein and the like. The housing 30 may also have a surface configuration that enhances bone growth such as, but not limited to surface knurling or roughening.

The open distal end 38 has internal threads 39 and is closeable with a cap 50 having at least a portion thereof that is electrically conductive. The cap 50 has a threaded end 52 which is threaded to match the internal threads 39 and secured to internal threads 39 by the use of a driver/wrench W or an equivalent tool.

Attached to and extending from the cap 50 is a casing 80 for containing electrical components discussed in greater detail below. The casing 80 is appropriately sized such that it fits within the central hollow chamber 36 of the housing 30 and occupies the least amount of space possible so as to limit interference with the bone fusion process. When the cap 50 is threadably coupled to the housing 30, the casing 80 is completely contained within the central hollow chamber 36 such that the EBGP implant 10 is a self-contained unit.

Referring to FIG. 2, the EBGP implant 10 is shown surgically implanted in the disc space S between the two adjacent vertebrae V₁ and V₂. At least a portion of the housing 30 is embedded into the bone of the adjacent vertebrae V₁ and V₂. However, it is appreciated that for the purpose of the present invention, the housing 30 need not be embedded into the bone of the vertebrae V₁ and V₂, but need only be placed adjacent to and be in contact with the vertebrae V₁ and V₂ in order to enable the EBGP implant 10 to conduct electrical current to the adjacent vertebrae V₁ and V₂.

It is to be understood that electrical current is a function of the time rate of change of electrical charge and the terms current and charge may be alternatively used depending upon context in describing the EBGP implants of the present invention. Further, as charge is proportional to the resistance encountered by the current, as bone growth occurs the resistance encountered by the current delivered to the bone mass will be increased, such that the charge will decrease. Also as the power supply depletes, the amount of current delivered over time will also decrease.

The hollow central chamber 36 can be filled with and may hold any natural or artificial osteoconductive, osteoinductive, osteogenic, or other fusion enhancing material. For example, bone material B harvested from the patient may be loaded into the central hollow chamber 36 as well as packed around the exterior of the housing 30, but within the intervertebral disc space S, wherein it is utilized in the spinal fusion process. An obturator or similar instrument may be used to create a space in the bone material B for receiving an object therein such as the casing 80. In this manner, the housing 30 may be filled with bone material B and then closed with the cap 50 to hold the bone material B within the hollow chamber 36 during surgical implantation.

The casing 80 itself, or a portion thereof, is made of an electrically conductive and surgically implantable material such as, but not limited to, titanium such that electrical current applied to the casing 80 may be transferred from the casing 80 to the bone material B that is contained within the hollow central chamber 36. The casing 80 may be remov-

ably attached to the cap 50 or may be permanently affixed. In the preferred embodiment, the casing 80 is electrically coupled to the cap 50. However, it is appreciated that the casing 80 may be electrically insulated from the cap 50 if it is not desired to conduct an electrical current to the cap 50 or if it is desired to conduct an electrical current to the cap 50 having a different polarity from the remainder of the casing 80.

Within the casing 80 are the electrical components comprising a power supply 60, control circuitry 70, a cathode lead 72, and an anode lead 74. Both the power supply 60 and the control circuitry 70 are fully implantable and hermetically sealed. The cathode lead 72 is electrically coupled to the cap 50 either directly or via the casing 80, such that when the cap 50 is threaded to the housing 30, negative electrical charge is transferred to the housing 30 such that the housing 30 itself becomes an active cathode. In this manner, the power supply 60 is electrically coupled to the housing 30 and is located at the site in which spinal fusion is desired. Thus, in this embodiment, the EBGp implant 10 is a self-contained unit, thereby eliminating the need to implant the power supply 60 and related control circuitry 70 at a remote location within the patient's body, as is the case with fusion stimulators of the prior art.

The control circuitry 70 preferably includes well known means for the delivery of a constant current source, providing a single, preset current in the range of 0.01 to 20 uA. Thus, neither attachment of multiple cathodes or variation in cathodic area will alter the current density delivered to the bone fusion mass. It is appreciated that the control circuitry 70 may also include a wave form generator, a voltage generator or a clock means for delivering intermittent pulses of current with out departing from the scope of the present invention. Alternatively, the control circuitry 70 may comprise means for providing various patterns of direct current, alternating current, pulsatile current, sinusoidal current, or electrical noise generated by current rather than constant, direct current in order to promote bone growth. It is further appreciated that the electrical components may also comprise any of the well-known devices currently available to electrically stimulate spinal fusion, such as but not limited to the stimulator available from EBI Medical Systems, Parsippany, N.J., and may also be any of the devices suitable for delivering electric current and suitable for implantation well-known by those skilled in the art.

The control circuitry 70 is powered by the fully implantable, hermetically sealed power supply 60 which may be any of the well-known power supplies known in the art and currently commercially available and used to electrically promote spinal fusion such as, but not limited to, the power supply by EBI Medical Systems, Parsippany, N.J. The power supply 60 also may contain circuitry for generating electrical charge in response to externally applied electromagnetic fields.

Referring to FIG. 3, alternatively, the power supply 60' may include battery recharge circuitry responsive to externally applied electromagnetic fields for recharging the battery. As a consequence, the overall size of the power supply 60' may be substantially reduced with a corresponding reduction in the size of the casing 80'. In this manner, any interference with the bone fusion process by the casing 80' is further reduced. Moreover, the longevity of the power supply 60' may be substantially increased as the power supply 60' may be recharged to extend its life beyond that of a conventional non-rechargeable battery having a fixed service life. As a result, the electric promotion of osteogenesis may be extended beyond the service life of conventional

prior art devices with their non-rechargeable batteries. Further, the rechargeable power supply 60' may be reduced in size as the service life may be extended indefinitely, compactness of power supply such that bone growth promoting bone material is not displaced which is essential for fusion.

Also shown in FIG. 3, is an alternative embodiment of the cap 50' which may be secured to the housing 30 by a spring fastening means 52' which engages the interior surface of the housing 30 once the spring fastening means 52' is inserted in the central hollow chamber 36. In this embodiment, the time required to load bone material B within the central hollow chamber 36 and the time to assemble the cap 50' to the housing 30 is significantly reduced.

As shown in FIG. 3A, the end of the casing 80 includes an insulated screw 90 made of a non-conductive material. The screw 90 has a threaded portion 92 which threadably attaches to the casing 80, and has an electrically conductive core 94 passing through the longitudinal axis of the screw 90. The electrically conductive core 94 terminates at one end into an electrically conductive head portion 96 and is at its other end electrically coupled to the anode lead 74. In this manner, the head portion 96 becomes the active anode for delivering positive electrical charge to an area of bone. As previously noted positive electrical charge inhibits osteogenesis, the head portion 96 preferably has the smallest possible size to limit the area of contact to bone exposed to positive charge to limit bone resorption and is positioned at a location where the presence of positive charge will least interfere with the fusion process.

In the preferred embodiment, the head portion 96 is located at the tip of the end of the casing 80 such that when the cap 50 is attached to the housing 30, the head portion 96, and thus the active anode, is at a location which least interferes with the electrical promotion of the bone material B contained with the central chamber 36 and has substantially no contact with the adjacent vertebrae V₁ and V₂ to which fusion is desired. An example of the electrical current present in the EBGp implant 10 is illustrated by the electrical field arrows in FIG. 2.

As the promotion of bone growth occurs by the application of negative electrical current, the promotion of bone growth may be controlled by the application of negative electrical current only to the location in which bone growth is desired. For example, if bone growth promotion is desired at a particular location, negative current may be transferred to the housing 30 or a portion thereof which is adjacent to and in contact with a desired site in order to accelerate the fusion process. In areas where bone growth is not desired, such as near the canal of the spine for example, positive current may be transferred to the desired site.

Referring again to FIG. 1, in order to conduct positive charge from the head portion 96 (the active anode) the presence of which is undesired within the central hollow chamber 36, an insulated screw 20 having a conductive inner core 22 is threaded through an opening 24 in the proximal end 40. The insulated screw 20 has a recess 26 for receiving and coupling to the head portion 96. In this manner, positive charge is conducted by the conductive inner core 22 to a point external to the housing 30.

Referring to FIGS. 4 and 5, a first alternative embodiment of the EBGp implant is shown and generally referred to by the numeral 110. The EBGp implant 110 comprises a housing 130 similar to the housing 30 described above, except that it has a proximal end 140 that is at least in part insulated from the remainder of the housing 130. The

housing 130 has macro-sized openings 142 to permit bone growth therethrough. Anode lead 174 from the power supply 160 and/or control circuitry 170 may be electrically coupled to the proximal end 140 of the housing 130 so that the proximal end 140 may be positively charged. To accomplish this, the proximal end 140 has a screw 120 having a conductive screw head 121, a conductive inner core 122, and an insulated stem portion 123 having a recess 126 for coupling to the head portion 196 (the active anode.) The inner core 122 conducts positive charge from the head portion 196 to the conductive screw head 121. The screw head 121 is insulated from the housing 130 by an insulated ring 125 made of a non-electrically conductive material so that the screw head 121 can conduct positive charge to a point external to the housing 130 so that at least a portion of the proximal end 140 of the housing 130 becomes positively charged as illustrated by the electrical field arrows in FIG. 4. In this manner, the area of positive charge may be varied in size by varying the area of the screw head 121, and thus the area of potential promotion of bone resorption is also variable. As shown in FIG. 4, the area of screw head 121 has been deliberately increased to inhibit bone formation in an area adjacent to the screw head 121.

The configuration of electrical charges shown in the EBGp implant 110 would be utilized when the housing 130 is installed from the posterior aspect of the spine toward the anterior aspect of the spine since the proximal end 140 of the EBGp implant 110 would be proximate to the spinal canal once implanted in the disc space S between two adjacent vertebrae V_1 and V_2 . By conducting positive charges to the proximal end 140 osteogenesis in the spinal canal which could compress the neural structures is inhibited.

It is appreciated that where negative electrical charge for the purpose of promoting bone growth is desired generally along the entire EBGp implant 110, then the positively charged screw 120 would have a screw head 121 proportionally much smaller in size to limit the area of positive electrical charge.

For the areas adjacent to the housing 130 in which bone growth and fusion is desired, the cathode lead 172 from the power supply 160 and/or control circuitry 170 is coupled to the casing 180 and negative charges are conducted to the housing 130 by the contact of the casing 180 and cap 150 with the housing 130 such that the housing 130 itself becomes an active cathode.

It is further appreciated that the delivering of positive charges and the negative charges may be reversed simply by interchanging the anode lead 174 and the cathode lead 172 coupling points to the housing 130, cap 150, distal end 140, or screw 120. In this way, negative charge may be applied and directed only to the particular areas in which bone growth is desired depending on the type of surgery, bone growth, and fusion desired.

Referring to FIG. 6, for example, if the EBGp implant 110 is installed from the anterior aspect toward the posterior aspect of the spine, the distal end 138 of the housing 130 would be proximate to the spinal canal. In order to prevent undesired bone growth near the spinal canal, the distal end 138 of the housing 130 or a portion thereof, which when implanted is adjacent to and in contact with the bone near the housing 130, may be insulated from the remainder of the housing 130. Further, the distal end 138 may be positively charged by being connected to the anode lead 174 of the generator 170 so that the proximal end 138 itself serves as an active anode. This can be accomplished by having an insulated screw 156 having an electrically conductive core

158. The electrically conductive core 158 becomes the active anode and delivers positive electrical charge to the adjacent bone area. Thus, bone area adjacent to and in contact with the distal end 138 would be exposed only to positive charge and not to bone growth promoting negative charge. Further, in order to minimize bone resorption, the diameter of the electrically conductive core 158 may extend from the insulated screw 156 and may be decreased in size to limit the bone area being exposed to positive electrical charge.

The application of different polarity charges to different areas of the housing 130 may also be accomplished by having the threads 152 of a cap 150 coated with a non-conductive material such as, but not limited to, a ceramic material in order to insulate the cap 150 from the remainder of the housing 130 such that the cap 150 becomes the active anode when connected to the anode lead 174 and is positively charged. This will prevent electrical promotion of bone growth in the vicinity of the cap 150 which is adjacent to the spinal canal and in contact with the bone near the spinal canal when implanted. However, it is appreciated that other means of insulating the distal end 138 well-known by those skilled in the art, may be employed so that the distal end 138 has a different charge than the remainder of the housing 130 or has no charge at all.

Referring to FIGS. 7, 8A and 8B, a second alternative embodiment of the EBGp implant of the present invention is shown and generally referred to by the numeral 210. The EBGp implant 210 comprises a housing 230 similar to the housing 30 described above. The exterior of the housing 230 has external threads 200 which are formed on the outer circumference of the housing 230 preferably in a helix.

As shown in FIG. 8A, the threads 200 of the housing 230 are electrically conductive and have a non-conductive insulating material 202 separating the threads 200. The insulating material 202 may be ceramic or polyethylene or any other biocompatible material that has electrical insulating properties. In this second alternative embodiment, the housing 230 may be completely or partially hollow and threads 200 serve as the active cathode to conduct negative charge to the bone area in which the housing 230 is implanted and any material that may be within the housing 230. As the insulating material 202 is interposed between the threads 200 themselves and between the housing 230 itself, the threads 200 are isolated from the remainder of the housing 230 and essentially act as a coil that surrounds the exterior of the housing 230. The threads 200 are electrically connected to the cathode lead 74 (see FIG. 1) of the control circuitry 70 described above and thus the threads 200 function as a cathode to deliver negative charge from the EBGp implant 210 to the vertebrae V adjacent to the housing 230 and material contained within the housing 230 if any. The advantage of this arrangement is that only the coil threads 200 are charged rather than the external housing 230 and since the beneficial electrical effect to some instance from each of the threads 200, the threads 200 are an effective cathode lead with less current drain than would be required to charge the external housing 230.

As shown in FIG. 8B, it is possible to configure the threads 200 such that at least a portion thereof passes through the insulating material 202 and communicates with the central chamber 236 so as to also conduct electric charge to any material contained within the housing 230 as illustrated by the electrical field arrows. This design requires that either the inward or outward portions of the threads 200 not be continuous such that the integrity of the housing 230 is not substantially reduced. The housing 230 has macro-size openings 242 to permit bone-growth therethrough.

Referring to FIGS. 9 and 10, a third alternative embodiment of the EBG implant 310 of the present invention is shown and is generally referred to by the numeral 310. In the third embodiment, the EBG implant 310 comprises a housing 330 similar to the housing 30 described above, having threads 300 and a wire 350 placed between the threads 300. The wire 350 is supported by a non conductive insulating material 360 that is placed between the threads 300 of the housing 330. The insulating material 360 has a groove 362 for receiving and holding the wire 350. The wire 350 is electrically coupled to a cathode lead such as the cathode lead 72 of the generator 70 (shown in FIG. 1) and is negatively charged such that wire 350 conducts bone growth promoting negative charge to the bone area of the adjacent vertebrae V_1 and V_2 adjacent to the coiled wire 350 and through the openings 342 to the fusion mass within the housing 330. The insulating material 360 prevents the body of the housing 330 from becoming electrically charged and prevents electrical conduction between wire 350 and threads 300 and housing 230 and any short circuiting of the coiled wire 350. In this manner, the area of the EBG implant 310 which is electively charged is limited to the coiled wire 350 to significantly reduce the total area which is electrically charged. However, as the coiled wire 350 essentially extends approximately the entire longitudinal length of the EBG implant 310, it is possible to deliver electrical charge to the entire area of bone adjacent to the EBG 310 to stimulate bone growth without any diminished effect. Thus, the EBG implant 310 is energy efficient since the amount of electrical current required to power the EBG implant 310 is substantially less than that required for an implant where the entire implant housing is charged.

Referring to FIGS. 11–15, a fourth alternative embodiment of the EBG implant 410 of the present invention is shown and is generally referred to by the numeral 410. In the fourth embodiment, the EBG implant 410 comprises a housing 430 similar to the housing 30 and having an opening 420 having an axis that is perpendicular to the longitudinal axis L of the housing 430. The opening 420 passes through the housing 430 and communicates with the central chamber 436 of the housing 430 and is surrounded by four structural support members 421, 422, 423, and 424. The opening 420 is covered by a lattice 415 at both ends. The lattice 415 has openings 416 sufficiently sized to permit bone growth there-through yet remains capable of retaining any natural or artificial bone growth material that may be contained within the hollow central chamber 436.

Referring to FIG. 15, an enlarged perspective view of structural support member 421 is shown. Each of the structural support members 421, 422, 423, and 424 are identical such that the description of one applies to each of the others. The structural support member 421 made of an electrically non-conductive material, has an upper arm 440 and a lower arm 442 that are placed in the hollow central chamber 436 and are secured to the spinal implant 430; a central portion 443 having a curved outer edge 444; and a grooved inner edge 446. The inner edge 446 of the structural support member 421 has a plurality of grooves 448 for receiving and holding a wire 425 capable of conducting electrical current. The plurality of grooves 448 are offset from each other and follow the curvature of the outer edge 444 of the structural support member 421.

Referring back to FIG. 11, preferably the four structural support members 421–424 are arranged around the outer perimeter of the opening 420 such that they are equidistant from one another. The wire 425 is placed within the grooves 448 and coiled about the four structural support members

421–424 to form a wire coil 426 around the perimeter of the opening 420 substantially along the entire vertical length of the opening 420 that is coaxial with the opening 420.

The wire coil 426 is electrically coupled to a cathode lead 472 and delivers and delivers a negative charge to the area surrounding within the torroid opening 420 such that bone growth is promoted and stimulated by the presence of negative charge along the inner and outer walls of the torroid shaped wire coil 426. When the EBG implant 410 is implanted between two adjacent vertebrae V_1 and V_2 , the opening 420 is filled with bone or bone promotion substances and the electrical promotion of bone growth causes bone of the adjacent vertebrae V_1 and V_2 to grow into and through the vertical opening 420 into that bone or bone promoting substances from one vertebra V_1 to the other vertebrae V_2 .

As shown in FIGS. 12 and 13, the control circuitry 470 and the power supply 460 are contained within the central chamber 436 of the housing 430 such that the EBG implant 410 is a self-contained unit. The wire coil 426 is coupled directly to a cathode lead 472 such that the wire coil 426 becomes negatively charged.

As shown in FIGS. 11 and 14, alternatively, the control circuitry 470 and power supply 460 may be implanted in an area of the patient's body remote from the EBG implant 410. The cathode lead 472 may be coupled directly to the wire coil 426 via lead wire 462 or may be coupled to the body of the housing 430 which is electrically conductive, and the wire coil 426 may also be electrically coupled to the housing 430 so that the housing 430 becomes electrically charged. However, it is preferred that the wire coil 426 be connected to either a wire coil such as described above in reference to FIGS. 9 and 10 or threads 200 as described above in reference to FIGS. 7, 8A and 8B. In this manner, efficient use of the power supply 460 is made as the drain is reduced without diminishing the effectiveness of the electrical promotion of bone growth as discussed above.

Referring to FIGS. 16 and 17 a fifth alternative embodiment of the EBG implant 510 of the present invention is shown. The EBG implant 510 comprises a housing 530 having a non-electrically conductive cap 550 threaded to its distal end 538, and a remotely implanted power supply 560 and control circuitry 570 connected to the housing 530. As the cap 550 is non-conductive, the housing 530 itself is negatively charged when coupled to the cathode lead 572 and the cap 550 has no electrical charge. The power supply 560 is electrically connected to the housing 530 by the cathode 572 which terminates at a connector 590 which is attached by a screw 592 to the housing 530.

It is appreciated that a remotely implanted power supply and/or related control circuitry may be used to deliver electric current to any of the embodiments described above that are self-contained units having an internal power supply and generator, without departing from the scope of the present invention.

Referring to FIGS. 18 and 19 a sixth alternative embodiment of the EBG implant 610 of the present invention is shown. In the sixth alternative embodiment, the EBG implant 610 comprises an electromagnetic field transmitter 600 that is worn external to the patient's body. The transmitter 600 has two portions 602 and 604 which are secured to the patient's body by a band 610 or any other suitable means, such that each portion 602, 604 is placed on opposite sides of the body at the exterior of the patient's body.

Implanted between two adjacent vertebrae V_1 and V_2 of the patient is a housing 630 similar to the housing 30

described above. The housing **630** is at least in part ferromagnetic and thereby capable of being inductively coupled to the electromagnetic fields transmitted by the transmitter **600**. The EBG implant **610** thereby may be inductively coupled to transmitter **600** and in this manner electromagnetic fields and resultant induced electrical currents in EBG implant **30** may be concentrated and directed to a location in which bone growth is desired without the need for surgically implanting and a power supply and/or control circuitry within the housing **630** or within the body of the patient. The non-ferromagnetic portion of the housing **630** also may be electrically conductive, which would make the housing **630** capable of being inductively coupled to the electromagnetic fields transmitted by the transmitter **600** as well as a conductor of electrical currents induced by said externally applied electromagnetic fields.

Similarly, if a rechargeable power supply **460** is contained within the housing **630**, the power supply **660** may be recharged with the application of external electromagnetic fields via the transmitter **600**. Thus, the power supply **660** could be much smaller in size as the power supply **660** may be repeatedly recharged. In this manner, both the housing **630** and the power supply **660** may be inductively coupled to the transmitter **600**, such that the housing **630** delivers electrical current to the adjacent bone mass and the power supply **660** is being recharged. After the transmitter **600** is no longer inductively coupled to the EBG implant **610** the replenished power supply **660** continues to deliver electrical current to the housing **630**. In this manner, the period of time in which a patient must wear the transmitter is substantially reduced to the period of time required to replenish the power supply **660**, while maintaining a continuous delivery of electrical current to the housing **630**.

As a further alternative, a rechargeable power supply **660** may be implanted remote to the spine, preferably subcutaneously, such that the power supply **660** is easily rechargeable via electromagnetic induction. The inductive coupling of a subcutaneous power supply **660** with the electromagnetic transmitter **600** overcomes the problems of infection associated with any direct coupling of a power supply to a power source. Further, subcutaneous implantation of the power supply **660** also facilitates explantation of the power supply **660** and further reduces the risk of infection to the patient. In contrast to implantations in other areas of the body.

Referring to FIG. 20 a seventh alternative embodiment of the EBG implant **710** of the present invention is shown. In the seventh embodiment, the housing **730** has a substantially rectangular hollow configuration and has a tapered distal end **738**. The housing **730** has an upper surface **750** and a parallel lower surface **752** and two side walls **754** and **756**. The housing **730** has a series of small openings **760** through the upper and lower surfaces **750** and **752** and through the side walls **754** and **756** for permitting bone growth there through. Contained within the spinal implant **730** are the power supply **760** and the control circuitry **770** so that the spinal implant **730** is a self-contained unit. The power supply **760** and/or control circuitry **770** are electrically coupled to the housing **730** by a cathode lead **762** and an anode lead **764**. The anode lead **764** is coupled to an insulating screw **756** having an electrically conductive core **758**. The insulating screw **756** is threaded into the EBG implant **710** and insulates the anode lead **764** from the rest of the EBG implant **710**.

Referring to FIG. 21 an eighth alternative embodiment of the EBG implant **810** of the present invention is shown. The EBG implant **810** is much like the seventh alternative

embodiment except that the housing **830** has a hollow rectangular configuration with raised engagement teeth **880** for engaging the bone of adjacent vertebra **V** and has a wire **850** similar to wire **350** described above, coiled about the housing **830**. The wire **850** is insulated from the housing **830** by an insulating material **860** having a groove **862** for receiving the wire **850**. The insulating material is identical to insulating material **360** discussed above. The EBG implant **810** is also a self-contained unit as the power supply **860** and/or the control circuitry **870** are contained within the hollow chamber of the spinal implant **830** and are electrically coupled to the wire **850**.

It is appreciated that the EBG implant of the present invention is not limited to use in the spinal fusion process but is also applicable to promoting almost any fusion of a large joint and for promoting healing of a fracture of any of the major bones of the body. Furthermore, the apparatus and method of the present invention may be incorporated into various total knee arthroplasty and total hip arthroplasty. Such implants may embody the above-described teachings without departing from the scope of the present invention. Such implants may be wholly or partially electrically conductive having a permanent or rechargeable power supply and related control circuitry located within the implant itself such that the implant is a self-contained unit. The use of a renewable power source is of great advantage with such implants in that the bone fusion process, or the healing of the larger bones such as the femur or hip, for example, may require a longer period of time for bone healing fusion than the service life of the implantable permanent power supplies that are presently utilized. As discussed above in greater detail, the recharging of the power source through external charging can extend the delivery of electrical current to the site in which induction of osteogenesis is desired for a substantially greater period of time.

Further, such implants may also comprise externally applied electromagnetic coils to generate an electromagnetic field that may be inductively coupled to the implant which in turn delivers electrical charges to the areas of bone adjacent to the implant as described in greater detail above and recharge the power supply by electromagnetic induction from an externally applied electrical field. All of such implants have the added advantage in that once implanted they become permanently entombed within the bone fusion mass after completion of the fusion process and need not be surgically removed.

While the present invention has been described in detail with regards to the preferred embodiments, it is appreciated that other variations of the present invention may be devised which do not depart from the inventive concept of the present invention.

What is claimed is:

1. A device for promoting bone growth comprising:
 - an implant having an outer surface sized for placement between and in contact with adjacent bone masses and having openings in said outer surface into which bone from the adjacent bone masses grows; and
 - means for energizing said implant to promote bone growth.
2. The device of claim 1 in which said energizing means is a power supply delivering an electric charge and further including control means for controlling delivery of said electrical charge.
3. The device of claim 2 in which said control means includes a wave form generator.
4. The device of claim 2 in which said control means includes a voltage generator.

17

5. The device of claim 2 in which said control means includes means for delivering intermittent pulses of current.

6. The device of claim 2 in which said control means includes means for providing alternating current.

7. The device of claim 2 in which said control means includes means for providing direct current.

8. The device of claim 2 in which said control means includes means for providing a sinusoidal current.

9. The device of claim 2 in which said control means includes means for generating electrical noise.

10. The device of claim 1 in which said energizing means comprises an electromagnetic field generator positioned external to the patient's body inductively coupled to said implant.

11. The device of claim 10 further including means for storing electrical current generated by said generator.

12. The device of claim 1 in which said implant has a substantially hollow chamber having at least one access opening.

13. The device of claim 12 in which said energizing means is contained within said implant.

14. The device of claim 13 in which said energizing means is a power supply delivering an electric charge and further including control means for controlling delivery of said electrical charge, said control means being contained within said implant.

15. The device of claim 12 further including a cap for closing said access opening of said hollow chamber.

16. The device of claim 15 in which said control means attaches to said cap.

17. The device of claim 16, in which said energizing means attaches to said cap.

18. The device of claim 1 in which said energizing means delivers negative electrical charge to a first portion of said implant, said first portion being electrically conductive for delivering said electrical charge to at least a portion of the adjacent bone masses.

19. The device of claim 18 in which said energizing means delivers positive electrical charge to a second portion of said implant, said second portion being electrically conductive for delivering said positive electrical charge.

20. The device of claim 1 in which said energizing means comprises a surgically implantable battery.

21. The device of claim 20 in which said battery is rechargeable.

22. The device of claim 1 in which said implant has a coil wrapped around said implant, said coil being electrically conductive.

23. The device of claim 22 in which said coil comprises a plurality of external threads on said outer surface of said implant.

24. The device of claim 23 in which said plurality of external threads are electrically coupled to said energizing means.

25. The device of claim 24 in which said implant has a hollow chamber, said plurality of external threads having means for conducting electrical current to said hollow chamber.

26. The device of claim 1 in which said implant has a passage between at least two of said openings such that said passage communicates with each of the adjacent bone masses to be joined; and

a conductive coil disposed proximate said passage, said coil being coupled to said energizing means.

27. The device of claim 26 in which said implant has a hollow chamber in communication with said passage and said coil.

18

28. The device of claim 27 in which said energizing means is contained within said implant.

29. The device of claim 28 in which said energizing means is a power supply delivering an electric charge and further including a control means for controlling delivery of said electrical charge, said control means being contained within said implant.

30. The device of claim 1 in which said implant is formed of a material which is stronger than the adjacent bone masses to be joined so as to support the adjacent bone masses.

31. The device of claim 1 in which said implant is for bone healing of a fractured large bone.

32. The device of claim 1 in which said implant is for fusion of a joint in the body.

33. The device of claim 1 in which said implant has a passage between a first of said openings in contact with one of the adjacent bone masses to be joined and a second of said openings in contact with another one of the adjacent bone masses to be joined; and

a conductive coil disposed proximate said passage, said coil being coupled to said energizing means and creating an electromagnetic field at said passage to promote bone growth through said passage.

34. The device of claim 1 in which said implant comprises a fusion promoting substance.

35. The device of claim 1 in which at least one of said openings of said implant contains fusion promoting materials for promoting bone ingrowth in continuity through said implant from one of the adjacent bone masses to the other of the adjacent bone masses.

36. The device of claim 1 in which said adjacent bone masses are vertebral bodies.

37. The device of claim 1 in which said openings of said implant allow bone growth to occur through said implant from the adjacent bone masses.

38. The device of claim 1 further comprising fusion promoting substances for promoting bone growth.

39. The device of claim 38, in which said implant permits bone growth to occur through said implant from one of the adjacent bone masses to the other of the adjacent bone masses.

40. The device of claim 1 in which said implant is an interbody spinal implant.

41. The device of claim 40 in which said implant is a fusion implant permitting bone growth around and through said implant.

42. The device of claim 1 in which said implant fits entirely between the adjacent bone masses.

43. The device of claim 1 in which said energizing means includes an electromagnetic wave generator.

44. The device of claim 1 in which said energizing means includes an electromagnetic energy generator.

45. The device of claim 1 in which said energizing means includes a magnetic field generator.

46. The device of claim 1 in which said source includes an electromagnetic wave generator.

47. The device of claim 1 in which said source includes an electromagnetic energy generator.

48. The device of claim 1 in which said source includes a magnetic field generator.

49. An assembly for delivering electric current to promote bone growth between adjacent vertebral bodies of a human spine, said assembly comprising:

an implant having an outer surface sized for placement between and in contact with the adjacent vertebral bodies, said implant having openings in said outer surface into which bone from the adjacent vertebral bodies grows; and

means for energizing said implant from a point external to a patient's body.

50. The assembly of claim 49 including means for delivering a charge of predetermined polarity to an area of bone adjacent to said implant.

51. The assembly of claim 49 further including means for storing electrical current generated by said energizing means within said implant.

52. The assembly of claim 49 wherein said outer surface of said implant has a length and a width, said length being less than the depth of the adjacent vertebral bodies and the width of said outer surface being less than the width of the adjacent vertebral bodies.

53. The assembly of claim 49 in which said implant is energized with and emits an electromagnetic field.

54. The assembly of claim 49 including a cathode lead integral with said implant.

55. The assembly of claim 49 in which said implant comprises a fusion promoting substance.

56. The assembly of claim 49 in which at least one of said openings of said implant contains fusion promoting materials for promoting bone ingrowth in continuity through said implant from one of the adjacent vertebral bodies to the other of the adjacent vertebral bodies.

57. The assembly of claim 49 in which said openings of said implant allow bone growth to occur through the interior of said implant.

58. The assembly of claim 49 further comprising fusion promoting substances for promoting bone growth.

59. The assembly of claim 58, in which said implant permits bone growth to occur through said implant from one of the adjacent vertebral bodies to the other of the adjacent vertebral bodies.

60. The assembly of claim 49 in which said implant fits entirely between the adjacent vertebral bodies.

61. The assembly of claim 49 in which said energizing means includes an electromagnetic wave generator.

62. The assembly of claim 49 in which said energizing means includes an electromagnetic energy generator.

63. The assembly of claim 49 in which said energizing means includes a magnetic field generator.

64. A method for promoting bone growth with an implant surgically implanted into the area of bone to be joined, comprising the steps of:

placing said implant between adjacent bone masses and in contact with the adjacent bone masses to be joined by bone growth; and

energizing said implant to promote bone growth in the adjacent bone masses and into said implant.

65. The method of claim 64 wherein the energizing step includes the step of negatively charging a first portion of said implant.

66. The medical device of claim 64 in which the adjacent bone masses are vertebral bodies.

67. The method of claim 65 further including the step of providing positive charge to a second portion of said implant to inhibit bone growth in an area adjacent to said second portion.

68. The method of claim 64 in which the placing step includes placing said implant having an outer surface with openings therein to allow bone growth to occur through said implant such that at least some of said openings are in contact with each of the adjacent bone masses.

69. The method of claim 68 further comprising the step of placing said implant comprising a fusion promoting substance to promote bone growth.

70. The method of claim 68 further comprising the step of loading at least one of said openings with fusion promoting

substances to promote bone growth into said implant from one of the adjacent bone masses to the other of the adjacent bone masses.

71. The method of claim 64 in which the placing step includes placing an interbody spinal fusion implant.

72. The method of claim 64 in which the placing step includes the step of fitting said implant entirely between the adjacent bone masses.

73. The method of claim 64 in which said step of energizing includes the step of generating an electromagnetic wave.

74. The method of claim 64 in which said step of energizing includes the step of generating electromagnetic energy.

75. The method of claim 64 in which said step of energizing includes the step of generating a magnetic field.

76. A self contained implantable medical device for promoting bone growth between bone masses, the medical device including:

an implant having an outer surface sized to be placed between and into contact with the bone masses;

a source of electrical charge contained within said implant; and

means for delivering charge from said source to the bone masses to promote bone growth into said implant.

77. The medical device of claim 76 wherein said delivering means includes means to deliver negative charge to a first location of bone mass and positive charge to a second location of bone mass.

78. The medical device of claim 76 in which said implant comprises a fusion promoting substance.

79. The medical device of claim 76 in which said implant has at least one opening containing fusion promoting materials for promoting bone ingrowth in continuity through said implant from one of the bone masses to the other of the bone masses.

80. The device of claim 76 in which said implant has an outer surface having openings therein to allow bone growth to occur through said implant from the bone masses.

81. The device of claim 80 further comprising fusion promoting substances for promoting bone growth.

82. The device of claim 80 in which said implant permits bone growth to occur through said implant from one of the bone masses to the other of the bone masses.

83. The device of claim 76 in which said implant is an interbody spinal fusion implant.

84. The device of claim 76 in which said implant fits entirely between the adjacent bone masses.

85. A self contained implantable medical device for placement between adjacent bone masses for promoting bone growth, comprising:

an implant for placement between and in contact with the adjacent bone masses, said implant having a first portion being electrically conductive for delivering electrical charge to at least a portion of the adjacent bone masses;

charge means contained within said implant for providing electrical charge at a predetermined polarity; and

means interposed between said charge means and said first portion for transferring charge from said charge means to said first portion, thereby promoting bone growth into said implant.

86. The medical device of claim 85 wherein said implant is generally cylindrical and has a substantially hollow chamber, said chamber having at least one access opening for receiving said charge means.

87. The device of claim 85 in which said implant is placed within a large bone.

88. The medical device of claim 85 in which the adjacent bone masses are vertebral bodies.

89. The medical device of claim 85 in which said implant comprises a fusion promoting substance.

90. The device of claim 85 in which said implant has at least one opening containing fusion promoting materials for promoting bone ingrowth in continuity through said implant from one of the adjacent bone masses to the other of the adjacent bone masses.

91. The device of claim 85 in which said implant does not extend substantially beyond the outer surface of the adjacent bone masses.

92. A device for promoting bone growth comprising:
an implant sized for placement between and in contact with adjacent bone masses along a contacting surface for each of the adjacent bone masses, said implant having exterior dimensions sized to be contained substantially between said contacting surfaces of the adjacent bone masses; and
means for energizing said implant to promote bone growth, said energizing means contained within said implant.

93. The device of claim 92 in which the adjacent bone masses are vertebral bodies.

94. The device of claim 92 in which said energizing means is a power supply delivering an electric charge.

95. The device of claim 92 in which said energizing means delivers negative electrical charge to a first portion of said implant, said first portion being electrically conductive for delivering said electrical charge to at least a portion of the adjacent bone masses.

96. The device of claim 95 in which said energizing means delivers positive electrical charge to a second portion of said implant.

97. The device of claim 92 in which said implant comprises a fusion promoting substance.

98. The device of claim 92 in which said openings of said implant allow bone growth to occur through said implant from the adjacent bone masses.

99. A method for promoting bone growth with an implant surgically implanted into the area of bone to be joined, comprising the steps of:

placing said implant between adjacent bone masses and in contact with the adjacent bone masses along a contacting surface for each of the adjacent bone masses, said implant having exterior dimensions sized to be contained substantially between said contacting surfaces of the adjacent bone masses; and
energizing said implant with a source contained within said implant to promote bone growth in the area of bone adjacent to said implant.

100. The method of claim 99 wherein the energizing step includes the step of negatively charging a first portion of said implant.

101. The method of claim 99 in which the placing step includes placing said implant having an outer surface with openings therein to allow bone growth to occur through said implant such that at least some of said openings are in contact with each of the adjacent bone masses.

102. The method of claim 101 further comprising the step of placing said implant comprising a fusion promoting substance to promote bone growth.

103. The method of claim 99 in which the placing step includes the step of fitting said implant entirely between the adjacent bone masses.

104. The method of claim 99 in which said step of energizing includes the step of generating electromagnetic energy.

105. A self contained implantable medical device for promoting bone growth between bone masses, the medical device including:

an implant sized to be placed between and into contact with the bone masses along a contacting surface for each of the bone masses, said implant having exterior dimensions sized to be contained substantially between said contacting surfaces of the bone masses;
a source of electrical charge contained within said implant; and
means for delivering charge from said source to the bone masses to promote growth.

106. The medical device of claim 105 wherein said delivering means includes means to deliver negative charge to a first location of bone mass and positive charge to a second location of bone mass.

107. The medical device of claim 105 in which said implant comprises a fusion promoting substance.

108. The medical device of claim 105 in which said implant has an outer surface with openings therein to allow bone growth to occur through said implant from the bone masses.

109. The device of claim 105 in which said implant fits entirely between the adjacent bone masses.

110. A device for promoting bone growth comprising:
an implant sized for placement between and in contact with adjacent bone masses along a contacting surface for each of the adjacent bone masses, said implant having exterior dimensions sized to be contained substantially between said contacting surfaces of the adjacent bone masses; and
means for energizing said implant from a point external to a patient's body to promote bone growth.

111. The device of claim 110 in which said energizing means includes a wave form generator.

112. The device of claim 110 in which said energizing means comprises an electromagnetic field generator positioned external to the patient's body inductively coupled to said implant.

113. The device of claim 112 further including means for storing electrical current generated by said generator.

114. The device of claim 110 in which said implant comprises a fusion promoting substance.

115. The device of claim 110 in which said adjacent bone masses are vertebral bodies.

116. The device of claim 110 in which said openings of said implant allow bone growth to occur through said implant from the adjacent bone masses.

117. An assembly for delivering electric current to promote bone growth between adjacent vertebral bodies of a human spine, said assembly comprising:

an implant sized for placement between and in contact with each of the adjacent vertebral bodies, said implant having exterior dimensions sized to be contained substantially within the depth and width of the vertebral bodies; and
means for energizing said implant from a point external to a patient's body.

118. The assembly of claim 117 in which said implant is energized with and emits an electromagnetic field.

119. The assembly of claim 117 in which said implant comprises a fusion promoting substance.

120. The assembly of claim 117 in which said openings of said implant allow bone growth to occur through the interior of said implant.

23

121. The assembly of claim 117 further comprising fusion promoting substances for promoting bone growth.

122. The assembly of claim 117 in which said implant fits entirely between the adjacent vertebral bodies.

123. A method for promoting bone growth with an implant surgically implanted into the area of bone masses to be joined, comprising the steps of:

placing said implant between adjacent bone masses and in contact with the adjacent bone masses along a contacting surface for each of the adjacent bone masses, said implant having exterior dimensions sized to be contained substantially between said contacting surfaces of the adjacent bone masses; and

energizing said implant from a point external to a patient's body to promote bone growth in the area of bone adjacent to said implant, so as promote the joining of the bone masses by bone growth.

24

124. The method of claim 123 wherein the energizing step includes the step of negatively charging a first portion of said implant.

125. The method of claim 123 in which the placing step includes placing said implant having an outer surface with openings therein to allow bone growth to occur through said implant such that at least some of said openings are in contact with each of the adjacent bone masses.

126. The method of claim 125 further comprising the step of placing said implant comprising a fusion promoting substance to promote bone growth.

127. The method of claim 123 in which the placing step includes the step of fitting said implant entirely between the adjacent bone masses.

128. The method of claim 123 in which said step of energizing includes the step of generating electromagnetic energy.

* * * * *

CERTIFICATE OF CORRECTION

PATENT NO: 6,120,502
DATED: September 19, 2000
INVENTOR: Gary Karlin Michelson

It is hereby certified that an error appears in the above-identified patent and that said Letters Patent is hereby corrected as shown below:

Column 17, Claim 16, line 1: change "said" to --a--;

Column 18, Claim 46, line 1: change "1" to --76--;

Claim 47, line 1: change "1" to --76--;

Claim 48, line 1: change "1" to --76--;

Column 19, Claim 66, line 1: change "64" to --30--;

Column 21, Claim 98, line 1: delete "said" (first occurrence); and change "of" (last occurrence) to

--in--;

Column 22, Claim 116, line 1: delete "said"; and change "of" (last occurrence) to --in--;

Claim 120, line 1: delete "said"; and change "of" (last occurrence) to --in--;

Column 23, Claim 123, penultimate line: after "as" insert --to--.

Signed and Sealed this

Twenty-fourth Day of April, 2001

Attest:



NICHOLAS P. GODICI

Attesting Officer

Acting Director of the United States Patent and Trademark Office